

2Mx32  
SDRAM 90FBGA  
(VDD/VDDQ 2.5V/1.8V or 2.5V/2.5V)

Revision 1.3

June 2002

**Revision History****Revision 0.0 (Feb. 2002, Preliminary)**

- First generation of 2Mx32 SDRAM F-die datasheet. (VDD 2.5V, VDDQ 1.8V & 2.5V).

**Revision 1.0 (April. 2002, Final)**

- Final version of 2Mx32 SDRAM F-die datasheet(VDD 2.5V, VDDQ 1.8V & 2.5V).

**Revision 1.1 (May. 2002, Final)**

- Addition of -1H code (100MHz, CL2).
- Changed DC VOH from 0.9xVDDQ to VDDQ-0.2V

**Revision 1.2 (May. 2002, Final)**

- Merged Pb with Pb free.

**Revision 1.3 (June. 2002, Final)**

- Correction of marking label typo.

## 512K x 32Bit x 4 Banks SDRAM

### FEATURES

- 2.5V Power Supply.
- LVCMOS compatible with multiplexed address.
- Four banks operation.
- MRS cycle with address key programs.
  - CAS latency (1, 2 & 3).
  - Burst length (1, 2, 4, 8 & Full page).
  - Burst type (Sequential & Interleave).
- All inputs are sampled at the positive going edge of the system clock .
- Burst read single-bit write operation.
- DQM for masking.
- Auto & self refresh.
- 64ms refresh period (4K cycle).
- Extended temperature range (-25°C to 85°C).  
Industrial Temperature range (-40°C to 85°C) for low power.
- 90balls FBGA.

### GENERAL DESCRIPTION

The K4S64323LF is 67,108,864 bits synchronous high data rate Dynamic RAM organized as 4 x 524,288 words by 32 bits, fabricated with SAMSUNG's high performance CMOS technology. Synchronous design allows precise cycle control with the use of system clock. I/O transactions are possible on every clock cycle. Range of operating frequencies, programmable burst lengths and programmable latencies allow the same device to be useful for a variety of high bandwidth and high performance memory system applications.

### ORDERING INFORMATION

Part No.	Max Freq.	Interface	Package
K4S64323LF-S(D)N/U/P75	133MHz(CL=3) <sup>*1</sup> 100MHz(CL=2)	LVCMOS	90FBGA Pb (Pb Free)
K4S64323LF-S(D)N/U/P1H	100MHz(CL=2)		
K4S64323LF-S(D)N/U/P1L	100MHz(CL=3) <sup>*2</sup>		
K4S64323LF-S(D)N/U/P15	66MHz(CL=2/3) <sup>*3</sup>		

-S(D)N ; Low Power, Operating Temperature ; -25°C~85°C.  
-S(D)U ; Super Low Power, Operating Temperature ; -25°C~85°C.  
-S(D)P ; Low Power, Operating Temperature ; -40°C~85°C.

#### Note :

1. In case of 55MHz Frequency, CL1 can be supported.
2. In case of 40MHz Frequency, CL1 can be supported.
3. In case of 33MHz Frequency, CL1 can be supported.

### FUNCTIONAL BLOCK DIAGRAM

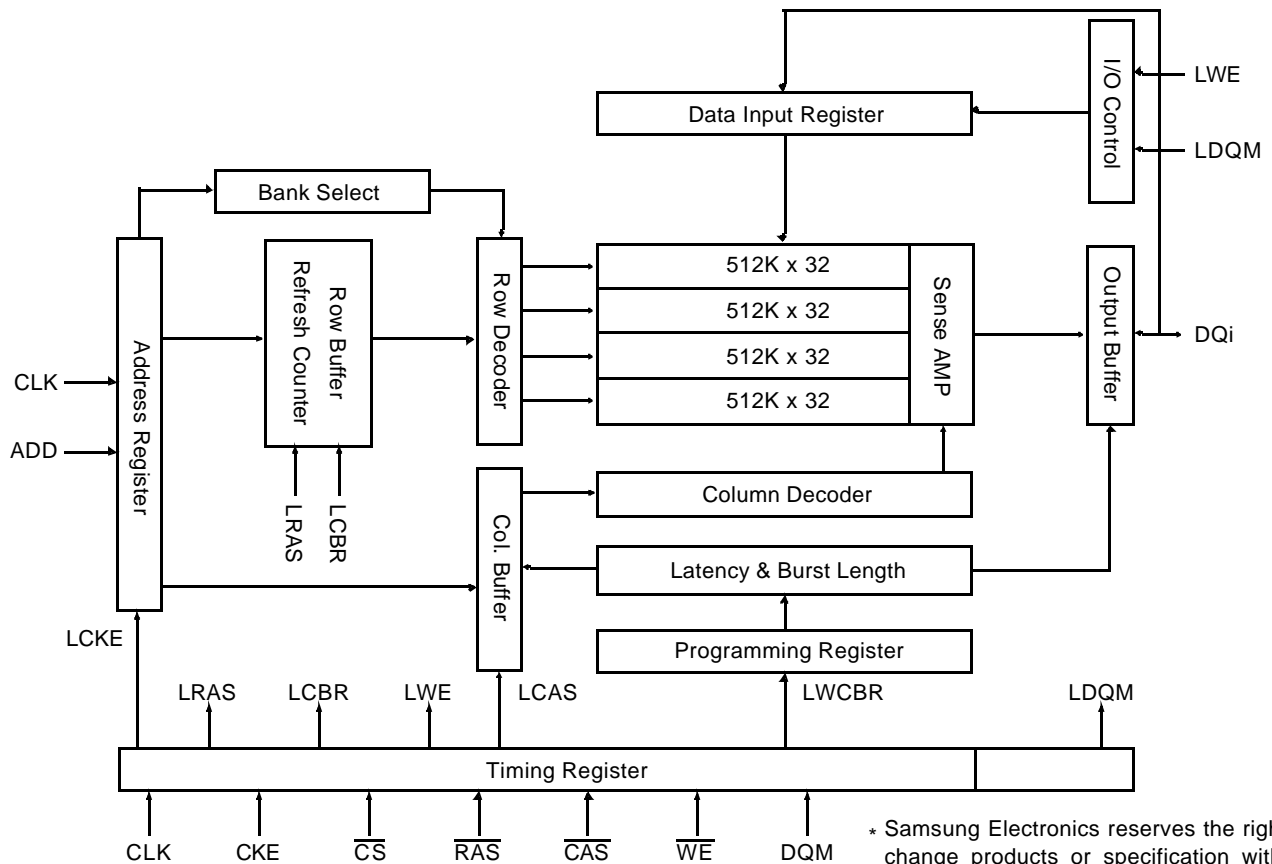

\* Samsung Electronics reserves the right to change products or specification without notice.

90-Ball FBGA Package Dimension and Pin Configuration

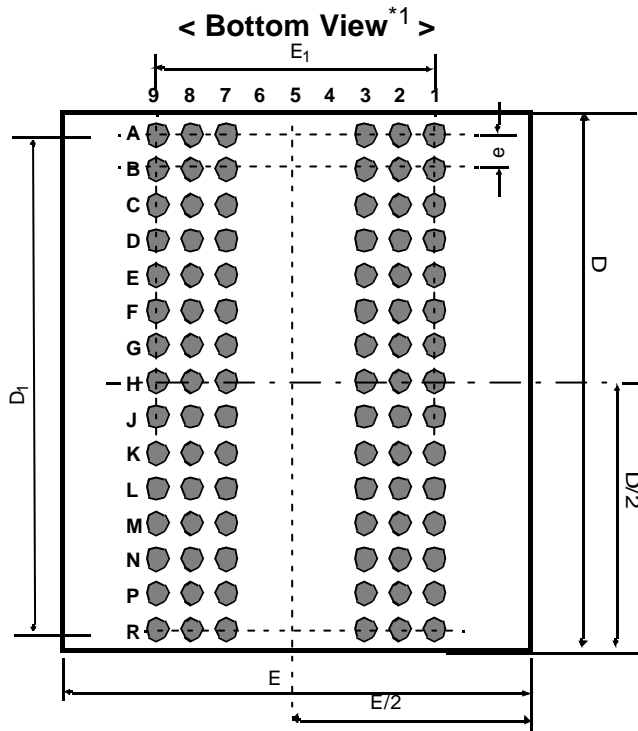

**< Top View \*2 >**

90Ball(6x15) CSP						
	1	2	3	7	8	9
A	DQ26	DQ24	Vss	VDD	DQ23	DQ21
B	DQ28	VDDQ	Vssq	VDDQ	Vssq	DQ19
C	Vssq	DQ27	DQ25	DQ22	DQ20	VDDQ
D	Vssq	DQ29	DQ30	DQ17	DQ18	VDDQ
E	VDDQ	DQ31	NC	NC	DQ16	Vssq
F	Vss	DQM3	A3	A2	DQM2	VDD
G	A4	A5	A6	A10	A0	A1
H	A7	A8	NC	NC	BA1	NC
J	CLK	CKE	A9	BA0	$\overline{CS}$	$\overline{RAS}$
K	DQM1	NC	NC	$\overline{CAS}$	$\overline{WE}$	DQM0
L	VDDQ	DQ8	Vss	VDD	DQ7	Vssq
M	Vssq	DQ10	DQ9	DQ6	DQ5	VDDQ
N	Vssq	DQ12	DQ14	DQ1	DQ3	VDDQ
P	DQ11	VDDQ	Vssq	VDDQ	Vssq	DQ4
R	DQ13	DQ15	Vss	VDD	DQ0	DQ2

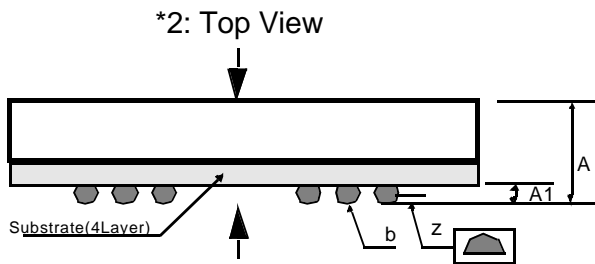

\*1: Bottom View

< Top View \*2 >

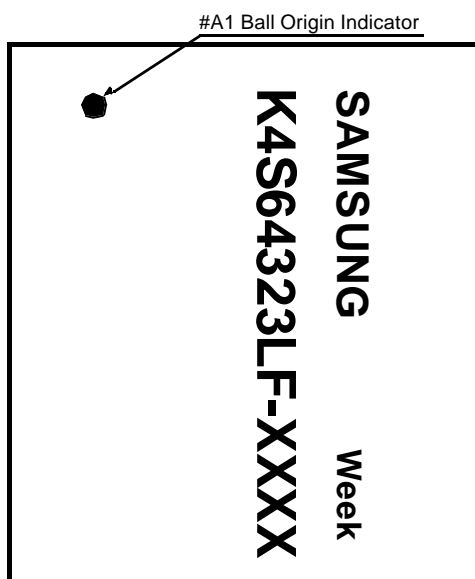

Pin Name	Pin Function
CLK	System Clock
$\overline{CS}$	Chip Select
CKE	Clock Enable
A0 ~ A10	Address
BA0 ~ BA1	Bank Select Address
$\overline{RAS}$	Row Address Strobe
$\overline{CAS}$	Column Address Strobe
$\overline{WE}$	Write Enable
DQM0 ~ DQM3	Data Input/Output Mask
DQ0 ~ 31	Data Input/Output
VDD/Vss	Power Supply/Ground
VDDQ/Vssq	Data Output Power/Ground

[Unit:mm]

Symbol	Min	Typ	Max
A	-	1.30	1.40
A1	0.30	0.35	0.40
E	-	11.00	-
E1	-	6.40	-
D	-	13.00	-
D1	-	11.20	-
e	-	0.80	-
b	0.40	0.45	0.50
z	-	-	0.10

## ABSOLUTE MAXIMUM RATINGS

Parameter	Symbol	Value	Unit
Voltage on any pin relative to Vss	V <sub>IN</sub> , V <sub>OUT</sub>	-1.0 ~ 3.6	V
Voltage on V <sub>DD</sub> supply relative to Vss	V <sub>DD</sub> , V <sub>DDQ</sub>	-1.0 ~ 3.6	V
Storage temperature	T <sub>STG</sub>	-55 ~ +150	°C
Power dissipation	P <sub>D</sub>	1	W
Short circuit current	I <sub>OS</sub>	50	mA

## Notes:

Permanent device damage may occur if ABSOLUTE MAXIMUM RATINGS are exceeded.  
 Functional operation should be restricted to recommended operating condition.  
 Exposure to higher than recommended voltage for extended periods of time could affect device reliability.

## DC OPERATING CONDITIONS

Recommended operating conditions (Voltage referenced to Vss = 0V, T<sub>A</sub> = -25°C to 85°C for Extended, -40°C to 85°C for Industrial)

Parameter	Symbol	Min	Typ	Max	Unit	Note
Supply voltage	V <sub>DD</sub>	2.3	2.5	2.7	V	
	V <sub>DDQ</sub>	1.65	-	2.7	V	
Input logic high voltage	V <sub>IH</sub>	0.8 x V <sub>DDQ</sub>	-	V <sub>DDQ</sub> + 0.3	V	1
Input logic low voltage	V <sub>IL</sub>	-0.3	0	0.3	V	2
Output logic high voltage	V <sub>OH</sub>	V <sub>DDQ</sub> - 0.2V	-	-	V	I <sub>OH</sub> = -0.1mA
Output logic low voltage	V <sub>OL</sub>	-	-	0.2	V	I <sub>OL</sub> = 0.1mA
Input leakage current	I <sub>LI</sub>	-10	-	10	uA	3

## Notes:

- V<sub>IH</sub> (max) = 3.0V AC. The overshoot voltage duration is ≤ 3ns.
- V<sub>IL</sub> (min) = -2.0V AC. The undershoot voltage duration is ≤ 3ns.
- Any input 0V ≤ V<sub>IN</sub> ≤ V<sub>DDQ</sub>.  
 Input leakage currents include Hi-Z output leakage for all bi-directional buffers with Tri-State outputs.
- Dout is disabled, 0V ≤ V<sub>OUT</sub> ≤ V<sub>DDQ</sub>.

CAPACITANCE (V<sub>DD</sub> = 2.5V, T<sub>A</sub> = 23°C, f = 1MHz, V<sub>REF</sub> = 0.9V ± 50 mV)

Pin	Symbol	Min	Max	Unit	Note
Clock	C <sub>CLK</sub>	-	4.0	pF	
$\overline{\text{RAS}}$ , $\overline{\text{CAS}}$ , $\overline{\text{WE}}$ , $\overline{\text{CS}}$ , CKE, DQM <sub>0</sub> ~ DQM <sub>3</sub>	C <sub>IN</sub>	-	4.0	pF	
Address(A <sub>0</sub> ~ A <sub>10</sub> , BA <sub>0</sub> ~ BA <sub>1</sub> )	C <sub>ADD</sub>	-	4.0	pF	
DQ <sub>0</sub> ~ DQ <sub>31</sub>	C <sub>OUT</sub>	-	6.0	pF	

## DC CHARACTERISTICS

Recommended operating conditions (Voltage referenced to  $V_{SS} = 0V$ ,  $T_A = -25^{\circ}C$  to  $85^{\circ}C$  for Extended,  $-40^{\circ}C$  to  $85^{\circ}C$  for Industrial)

Parameter	Symbol	Test Condition	Version				Unit	Note
			-75	-1H	-1L	-15		
Operating Current (One Bank Active)	I <sub>CC1</sub>	Burst length = 1 $t_{RC} \geq t_{RC}(\min)$ $I_O = 0 \text{ mA}$	70	70	65	60	mA	1
Precharge Standby Current in power-down mode	I <sub>CC2P</sub>	$CKE \leq V_{IL}(\max)$ , $t_{CC} = 10\text{ns}$	0.5				mA	
	I <sub>CC2PS</sub>	$CKE \ \& \ CLK \leq V_{IL}(\max)$ , $t_{CC} = \infty$	0.5					
Precharge Standby Current in non power-down mode	I <sub>CC2N</sub>	$CKE \geq V_{IH}(\min)$ , $\overline{CS} \geq V_{IH}(\min)$ , $t_{CC} = 10\text{ns}$ Input signals are changed one time during 20ns	10				mA	
	I <sub>CC2NS</sub>	$CKE \geq V_{IH}(\min)$ , $CLK \leq V_{IL}(\max)$ , $t_{CC} = \infty$ Input signals are stable	7					
Active Standby Current in power-down mode	I <sub>CC3P</sub>	$CKE \leq V_{IL}(\max)$ , $t_{CC} = 10\text{ns}$	5				mA	
	I <sub>CC3PS</sub>	$CKE \ \& \ CLK \leq V_{IL}(\max)$ , $t_{CC} = \infty$	5					
Active Standby Current in non power-down mode (One Bank Active)	I <sub>CC3N</sub>	$CKE \geq V_{IH}(\min)$ , $\overline{CS} \geq V_{IH}(\min)$ , $t_{CC} = 10\text{ns}$ Input signals are changed one time during 20ns	20				mA	
	I <sub>CC3NS</sub>	$CKE \geq V_{IH}(\min)$ , $CLK \leq V_{IL}(\max)$ , $t_{CC} = \infty$ Input signals are stable	20					
Operating Current	I <sub>CC4</sub>	$I_O = 0 \text{ mA}$ , Page burst	85	70	70	60	mA	1
Refresh Current	I <sub>CC5</sub>	$t_{RC} \geq t_{RC}(\min)$	115	110	100	80	mA	2
Self Refresh Current	I <sub>CC6</sub>	$CKE \leq 0.2V$	-S(D)N/P				uA	3
			-S(D)U					

## Notes :

1. Measured with outputs open.
2. Refresh period is 64ms.
3. K4S64323LF-S(D)N/P\*\*
4. K4S64323LF-S(D)U\*\*
5. Unless otherwise noted, input swing level is CMOS( $V_{IH}/V_{IL} = V_{DDQ}/V_{SSQ}$ ).

## AC OPERATING TEST CONDITIONS ( $V_{DD} = 2.5V \pm 0.2V$ , $T_A = -25^\circ C$ to $85^\circ C$ for Extended, $-40^\circ C$ to $85^\circ C$ for Industrial)

Parameter	Value	Unit
AC input levels ( $V_{ih}/V_{il}$ )	$0.9 \times V_{DDQ} / 0.2$	V
Input timing measurement reference level	$0.5 \times V_{DDQ}$	V
Input rise and fall time	$t_r/t_f = 1/1$	ns
Output timing measurement reference level	$0.5 \times V_{DDQ}$	V
Output load condition	See Fig. 2	

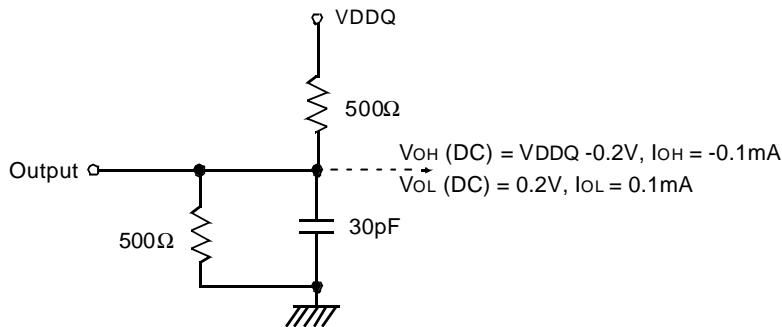

(Fig. 1) DC Output Load Circuit

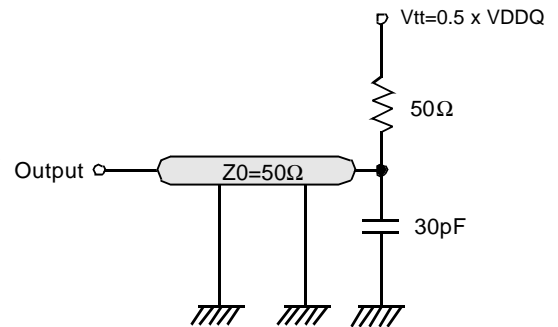

(Fig. 2) AC Output Load Circuit

## OPERATING AC PARAMETER (AC operating conditions unless otherwise noted)

Parameter	Symbol	Version				Unit	Note
		- 75	-1H	-1L	-15		
Row active to row active delay	$t_{RRD}(\min)$	15	20	20	30	ns	1
$\overline{RAS}$ to $\overline{CAS}$ delay	$t_{RCD}(\min)$	20	20	24	30	ns	1
Row precharge time	$t_{RP}(\min)$	20	20	24	30	ns	1
Row active time	$t_{RAS}(\min)$	45	50	60	60	ns	1
	$t_{RAS}(\max)$	100				us	
Row cycle time	$t_{RC}(\min)$	65	70	84	90	ns	1
Last data in to row precharge	$t_{RDL}(\min)$	10		15		ns	2
Last data in to Active delay	$t_{DAL}(\min)$	$t_{RDL} + t_{RP}$				-	3
Last data in to new col. address delay	$t_{CDL}(\min)$	1				CLK	2
Last data in to burst stop	$t_{BDL}(\min)$	1				CLK	2
Col. address to col. address delay	$t_{CCD}(\min)$	1				CLK	4
Number of valid output data	CAS latency=3	2				ea	5
	CAS latency=2	1					
	CAS latency=1	-		0			

### Notes :

- The minimum number of clock cycles is determined by dividing the minimum time required with clock cycle time and then rounding off to the next higher integer.
- Minimum delay is required to complete write.
- Minimum  $2CLK$   $t_{DAL}$  is required to complete row precharge.
- All parts allow every cycle column address change.
- In case of row precharge interrupt, auto precharge and read burst stop.

**AC CHARACTERISTICS**(AC operating conditions unless otherwise noted)

Parameter		Symbol	- 75		-1H		-1L		- 15		Unit	Note
			Min	Max	Min	Max	Min	Max	Min	Max		
CLK cycle time	CAS latency=3	tcc	7.5	1000	10	1000	10	1000	15	1000	ns	1
	CAS latency=2		10		10		12		15			
	CAS latency=1		-		-		25		30			
CLK to valid output delay	CAS latency=3	tsac		5.4		7		7		9	ns	1,2
	CAS latency=2			7		7		8		9		
	CAS latency=1			-		-		20		24		
Output data hold time	CAS latency=3	toH	2.5		2.5		2.5		2.5		ns	2
	CAS latency=2		2.5		2.5		2.5		2.5			
	CAS latency=1		-		-		2.5		2.5			
CLK high pulse width		tCH	2.5		3		3		3.5		ns	3
CLK low pulse width		tCL	2.5		3		3		3.5		ns	3
Input setup time		tSS	2.0		2.5		2.5		3.5		ns	3
Input hold time		tSH	1.0		1.5		1.5		2.0		ns	3
CLK to output in Low-Z		tSLZ	1		1		1		1		ns	2
CLK to output in Hi-Z	CAS latency=3	tSHZ		5.4		7		7		9	ns	
	CAS latency=2			7		7		8		9		
	CAS latency=1			-		-		20		24		

**Notes :**

- Parameters depend on programmed CAS latency.
- If clock rising time is longer than 1ns,  $(tr/2-0.5)$ ns should be added to the parameter.
- Assumed input rise and fall time ( $tr$  &  $tf$ ) = 1ns.  
If  $tr$  &  $tf$  is longer than 1ns, transient time compensation should be considered, i.e.,  $[(tr + tf)/2-1]$ ns should be added to the parameter.



**SIMPLIFIED TRUTH TABLE** (V=Valid, X=Don't Care, H=Logic High, L=Logic Low)

COMMAND		CKEn-1	CKEn	$\overline{CS}$	$\overline{RAS}$	$\overline{CAS}$	$\overline{WE}$	DQM	BA <sub>0,1</sub>	A <sub>10/AP</sub>	A <sub>9 ~ A<sub>0</sub></sub>	Note
Register	Mode Register Set	H	X	L	L	L	L	X	OP CODE			1, 2
Refresh	Auto Refresh	H	H	L	L	L	H	X	X			3
	Entry		L	L	L	H	X		X			3
	Self Refresh	L	H	L	H	H		H	X	X		
				Exit	H	X	X	X		X		
Bank Active & Row Addr.		H	X	L	L	H	H	X	V	Row Address		
Read & Column Address	Auto Precharge Disable	H	X	L	H	L	H	X	V	L	Column Address (A <sub>0</sub> ~A <sub>7</sub> )	4
	Auto Precharge Enable									H		4, 5
Write & Column Address	Auto Precharge Disable	H	X	L	H	L	L	X	V	L	Column Address (A <sub>0</sub> ~A <sub>7</sub> )	4
	Auto Precharge Enable									H		4, 5
Burst Stop		H	X	L	H	H	L	X	X			6
Precharge	Bank Selection	H	X	L	L	H	L	X	V	L	X	
	All Banks								X	H		
Clock Suspend or Active Power Down	Entry	H	L	H	X	X	X	X	X			
				L	V	V	V					
Precharge Power Down Mode	Entry	H	L	H	X	X	X	X	X			
				L	H	H	H					
	Exit	L	H	H	X	X	X	X				
				L	V	V	V					
DQM		H	X					V	X		7	
No Operation Command		H	X	H	X	X	X	X	X			
				L	H	H	H					

**Note :**

- OP Code : Operand Code  
A<sub>0</sub> ~ A<sub>10</sub> & BA<sub>0</sub> ~ BA<sub>1</sub> : Program keys. (@MRS)
- MRS can be issued only at all banks precharge state.  
A new command can be issued after 2 CLK cycles of MRS.
- Auto refresh functions are the same as CBR refresh of DRAM.  
The automatical precharge without row precharge command is meant by "Auto".  
Auto/self refresh can be issued only at all banks precharge state.
- BA<sub>0</sub> ~ BA<sub>1</sub> : Bank select addresses.  
If both BA<sub>0</sub> and BA<sub>1</sub> are "Low" at read, write, row active and precharge, bank A is selected.  
If BA<sub>0</sub> is "Low" and BA<sub>1</sub> is "High" at read, write, row active and precharge, bank B is selected.  
If BA<sub>0</sub> is "High" and BA<sub>1</sub> is "Low" at read, write, row active and precharge, bank C is selected.  
If both BA<sub>0</sub> and BA<sub>1</sub> are "High" at read, write, row active and precharge, bank D is selected.  
If A<sub>10/AP</sub> is "High" at row precharge, BA<sub>0</sub> and BA<sub>1</sub> are ignored and all banks are selected.
- During burst read or write with auto precharge, new read/write command can not be issued.  
Another bank read/write command can be issued after the end of burst.  
New row active of the associated bank can be issued at t<sub>RP</sub> after the end of burst.
- Burst stop command is valid at every burst length.
- DQM sampled at the positive going edge of CLK masks the data-in at that same CLK in write operation (Write DQM latency is 0), but in read operation it makes the data-out Hi-Z state after 2 CLK cycles. (Read DQM latency is 2).

## A. MODE REGISTER FIELD TABLE TO PROGRAM MODES

Register Programmed with Normal MRS

Address	BA0 ~ BA1*1	A10/AP	A9	A8	A7	A6	A5	A4	A3	A2	A1	A0
Function	"0" Setting for Normal MRS	RFU	W.B.L	Test Mode		CAS Latency			BT	Burst Length		

### Normal MRS Mode

Test Mode			CAS Latency				Burst Type			Burst Length				
A8	A7	Type	A6	A5	A4	Latency	A3	Type		A2	A1	A0	BT=0	BT=1
0	0	Mode Register Set	0	0	0	Reserved	0	Sequential		0	0	0	1	1
0	1	Reserved	0	0	1	1	1	Interleave		0	0	1	2	2
1	0	Reserved	0	1	0	2	Mode Select			0	1	0	4	4
1	1	Reserved	0	1	1	3	BA1	BA0	Mode	0	1	1	8	8
Write Burst Length			1	0	0	Reserved	0	0	Setting for Normal MRS	1	0	0	Reserved	Reserved
A9	Length		1	0	1	Reserved				1	0	1	Reserved	Reserved
0	Burst		1	1	0	Reserved				1	1	0	Reserved	Reserved
1	Single Bit		1	1	1	Reserved				1	1	1	Full Page	Reserved

Full Page Length : 256(x32)

## B. Power Up Sequence

1. Apply power and start clock, Attempt to maintain CKE= "H", DQM= "H" and the other pins are NOP condition at the inputs.
2. Power is applied to VDD and VDDQ (simultaneously).
3. Maintain stable power, stable clock and NOP input condition for a minimum of 200us.
4. Issue precharge commands for all banks of the devices.
5. Issue 2 or more auto-refresh commands.
6. Issue a mode register set command to initialize the mode register.

**Note :** 1. In order to assert normal MRS, BA0 and BA1 should set "0" absolutely.

### Note :

1. Samsung are not designed or manufactured for use in a device or system that is used under circumstance in which human life is potentially at stake. Please contact to the memory marketing team in samsung electronics when considering the use of a product contained herein for any specific purpose, such as medical, aerospace, nuclear, military, vehicular or undersea repeater use.

**C. BURST SEQUENCE**

**1. BURST LENGTH = 4**

Initial Address		Sequential				Interleave			
A <sub>1</sub>	A <sub>0</sub>								
0	0	0	1	2	3	0	1	2	3
0	1	1	2	3	0	1	0	3	2
1	0	2	3	0	1	2	3	0	1
1	1	3	0	1	2	3	2	1	0

**2. BURST LENGTH = 8**

Initial Address			Sequential								Interleave							
A <sub>2</sub>	A <sub>1</sub>	A <sub>0</sub>																
0	0	0	0	1	2	3	4	5	6	7	0	1	2	3	4	5	6	7
0	0	1	1	2	3	4	5	6	7	0	1	0	3	2	5	4	7	6
0	1	0	2	3	4	5	6	7	0	1	2	3	0	1	6	7	4	5
0	1	1	3	4	5	6	7	0	1	2	3	2	1	0	7	6	5	4
1	0	0	4	5	6	7	0	1	2	3	4	5	6	7	0	1	2	3
1	0	1	5	6	7	0	1	2	3	4	5	4	7	6	1	0	3	2
1	1	0	6	7	0	1	2	3	4	5	6	7	4	5	2	3	0	1
1	1	1	7	0	1	2	3	4	5	6	7	6	5	4	3	2	1	0

## D. DEVICE OPERATIONS

### ADDRESSES of 64Mb

#### BANK ADDRESSES (BA<sub>0</sub> ~ BA<sub>1</sub>)

##### : In case x 16

This SDRAM is organized as four independent banks of 1,048,576 words x 16 bits memory arrays. The BA<sub>0</sub> ~ BA<sub>1</sub> inputs are latched at the time of assertion of  $\overline{\text{RAS}}$  and  $\overline{\text{CAS}}$  to select the bank to be used for the operation. The bank addresses BA<sub>0</sub> ~ BA<sub>1</sub> are latched at bank active, read, write, mode register set and pre-charge operations.

##### : In case x 32

This SDRAM is organized as four independent banks of 524,288 words x 32 bits memory arrays. The BA<sub>0</sub> ~ BA<sub>1</sub> inputs are latched at the time of assertion of  $\overline{\text{RAS}}$  and  $\overline{\text{CAS}}$  to select the bank to be used for the operation. The bank addresses BA<sub>0</sub> ~ BA<sub>1</sub> are latched at bank active, read, write, mode register set and pre-charge operations.

#### ADDRESS INPUTS (A<sub>0</sub> ~ A<sub>11</sub>)

##### : In case x 16

The 20 address bits are required to decode the 1,048,576 word locations are multiplexed into 12 address input pins (A<sub>0</sub> ~ A<sub>11</sub>). The 12 bit row addresses are latched along with  $\overline{\text{RAS}}$  and BA<sub>0</sub> ~ BA<sub>1</sub> during bank activate command. The 8 bit column addresses are latched along with  $\overline{\text{CAS}}$ ,  $\overline{\text{WE}}$  and BA<sub>0</sub> ~ BA<sub>1</sub> during read or write command.

##### : In case x 32

The 19 address bits are required to decode the 524,288 word locations are multiplexed into 11 address input pins (A<sub>0</sub> ~ A<sub>10</sub>). The 11 bit row addresses are latched along with  $\overline{\text{RAS}}$  and BA<sub>0</sub> ~ BA<sub>1</sub> during bank activate command. The 8 bit column addresses are latched along with  $\overline{\text{CAS}}$ ,  $\overline{\text{WE}}$  and BA<sub>0</sub> ~ BA<sub>1</sub> during read or write command.

### ADDRESSES of 128Mb

#### BANK ADDRESSES (BA<sub>0</sub> ~ BA<sub>1</sub>)

##### : In case x 16

This SDRAM is organized as four independent banks of 2,097,152 words x 16 bits memory arrays. The BA<sub>0</sub> ~ BA<sub>1</sub> inputs are latched at the time of assertion of  $\overline{\text{RAS}}$  and  $\overline{\text{CAS}}$  to select the bank to be used for the operation. The bank addresses BA<sub>0</sub> ~ BA<sub>1</sub> are latched at bank active, read, write, mode register set and pre-charge operations.

##### : In case x 32

This SDRAM is organized as four independent banks of 1,048,576 words x 32 bits memory arrays. The BA<sub>0</sub> ~ BA<sub>1</sub> inputs are latched at the time of assertion of  $\overline{\text{RAS}}$  and  $\overline{\text{CAS}}$  to select the bank to be used for the operation. The bank addresses BA<sub>0</sub> ~ BA<sub>1</sub> are latched at bank active, read, write, mode register set and pre-charge operations.

#### ADDRESS INPUTS (A<sub>0</sub> ~ A<sub>11</sub>)

##### : In case x 16

The 21 address bits are required to decode the 2,097,152 word locations are multiplexed into 12 address input pins (A<sub>0</sub> ~ A<sub>11</sub>). The 12 bit row addresses are latched along with  $\overline{\text{RAS}}$  and BA<sub>0</sub> ~ BA<sub>1</sub> during bank activate command. The 9 bit column addresses are latched along with  $\overline{\text{CAS}}$ ,  $\overline{\text{WE}}$  and BA<sub>0</sub> ~ BA<sub>1</sub> during read or write command.

##### : In case x 32

The 20 address bits are required to decode the 1,048,576 word locations are multiplexed into 12 address input pins (A<sub>0</sub> ~ A<sub>11</sub>). The 12 bit row addresses are latched along with  $\overline{\text{RAS}}$  and BA<sub>0</sub> ~ BA<sub>1</sub> during bank activate command. The 8 bit column addresses are latched along with  $\overline{\text{CAS}}$ ,  $\overline{\text{WE}}$  and BA<sub>0</sub> ~ BA<sub>1</sub> during read or write command.

## D. DEVICE OPERATIONS (continued)

### CLOCK (CLK)

The clock input is used as the reference for all SDRAM operations. All operations are synchronized to the positive going edge of the clock. The clock transitions must be monotonic between  $V_{IL}$  and  $V_{IH}$ . During operation with  $\overline{CKE}$  high all inputs are assumed to be in a valid state (low or high) for the duration of set-up and hold time around positive edge of the clock in order to function well Q perform and  $I_{cc}$  specifications.

### CLOCK ENABLE (CKE)

The clock enable (CKE) gates the clock onto SDRAM. If CKE goes low synchronously with clock (set-up and hold time are the same as other inputs), the internal clock is suspended from the next clock cycle and the state of output and burst address is frozen as long as the CKE remains low. All other inputs are ignored from the next clock cycle after CKE goes low. When all banks are in the idle state and CKE goes low synchronously with clock, the SDRAM enters the power down mode from the next clock cycle. The SDRAM remains in the power down mode ignoring the other inputs as long as CKE remains low. The power down exit is synchronous as the internal clock is suspended. When CKE goes high at least "1CLK + t<sub>ss</sub>" before the high going edge of the clock, then the SDRAM becomes active from the same clock edge accepting all the input commands.

### NOP and DEVICE DESELECT

When  $\overline{RAS}$ ,  $\overline{CAS}$  and  $\overline{WE}$  are high, the SDRAM performs no operation (NOP). NOP does not initiate any new operation, but is needed to complete operations which require more than single clock cycle like bank activate, burst read, auto refresh, etc. The device deselect is also a NOP and is entered by asserting  $\overline{CS}$  high.  $\overline{CS}$  high disables the command decoder so that  $\overline{RAS}$ ,  $\overline{CAS}$ ,  $\overline{WE}$  and all the address inputs are ignored.

### DQM OPERATION

The DQM is used to mask input and output operations. It works similar to  $\overline{OE}$  during read operation and inhibits writing during write operation. The read latency is two cycles from DQM and zero cycle for write, which means DQM masking occurs two cycles later in read cycle and occurs in the same cycle during write cycle. DQM operation is synchronous with the clock. The DQM signal is important during burst interruptions of write with read or precharge in the SDRAM. Due to asynchronous nature of the internal write, the DQM operation is critical to avoid unwanted or incomplete writes when the complete burst write is not required. Please refer to DQM timing diagram also.

### MODE REGISTER SET (MRS)

The mode register stores the data for controlling the various operating modes of SDRAM. It programs the CAS latency, burst type, burst length, test mode and various vendor specific options to make SDRAM useful for variety of different applications. The default value of the mode register is not defined, therefore the mode register must be written after power up to operate the SDRAM. The mode register is written by asserting low on  $\overline{CS}$ ,  $\overline{RAS}$ ,  $\overline{CAS}$  and  $\overline{WE}$  (The SDRAM should be in active mode with  $\overline{CKE}$  already high prior to writing the mode register). The state of address pins  $A_0 \sim A_n$  and  $BA_0 \sim BA_1$  in the same cycle as  $\overline{CS}$ ,  $\overline{RAS}$ ,  $\overline{CAS}$  and  $\overline{WE}$  going low is the data written in the mode register. Two clock cycles is required to complete the write in the mode register. The mode register contents can be changed using the same command and clock cycle requirements during operation as long as all banks are in the idle state. The mode register is divided into various fields depending on the fields of functions. The burst length field uses  $A_0 \sim A_2$ , burst type uses  $A_3$ , CAS latency (read latency from column address) use  $A_4 \sim A_6$ , vendor specific options or test mode use  $A_7 \sim A_8$ ,  $A_{10}/AP \sim A_n$  and  $BA_0 \sim BA_1$ . The write burst length is programmed using  $A_9$ .  $A_7 \sim A_8$ ,  $A_{10}/AP \sim A_n$  and  $BA_0 \sim BA_1$  must be set to low for normal SDRAM operation. Refer to the table for specific codes for various burst length, burst type and CAS latencies.

## D. DEVICE OPERATIONS (continued)

### **BANK ACTIVATE.**

The bank activate command is used to select a random row in an idle bank. By asserting low on  $\overline{\text{RAS}}$  and  $\overline{\text{CS}}$  with desired row and bank address, a row access is initiated. The read or write operation can occur after a time delay of  $t_{\text{RCD}}(\text{min})$  from the time of bank activation.  $t_{\text{RCD}}$  is an internal timing parameter of SDRAM, therefore it is dependent on operating clock frequency. The minimum number of clock cycles required between bank activate and read or write command should be calculated by dividing  $t_{\text{RCD}}(\text{min})$  with cycle time of the clock and then rounding off the result to the next higher integer. The SDRAM has four internal banks in the same chip and shares part of the internal circuitry to reduce chip area, therefore it restricts the activation of four banks simultaneously. Also the noise generated during sensing of each bank of SDRAM is high, requiring some time for power supplies to recover before another bank can be sensed reliably.  $t_{\text{RRD}}(\text{min})$  specifies the minimum time required between activating different bank. The number of clock cycles required between different bank activation must be calculated similar to  $t_{\text{RCD}}$  specification. The minimum time required for the bank to be active to initiate sensing and restoring the complete row of dynamic cells is determined by  $t_{\text{RAS}}(\text{min})$ . Every SDRAM bank activate command must satisfy  $t_{\text{RAS}}(\text{min})$  specification before a precharge command to that active bank can be asserted. The maximum time any bank can be in the active state is determined by  $t_{\text{RAS}}(\text{max})$ . The number of cycles for both  $t_{\text{RAS}}(\text{min})$  and  $t_{\text{RAS}}(\text{max})$  can be calculated similar to  $t_{\text{RCD}}$  specification.

### **BURST READ**

The burst read command is used to access burst of data on consecutive clock cycles from an active row in an active bank. The burst read command is issued by asserting low on  $\overline{\text{CS}}$  and  $\overline{\text{CAS}}$  with  $\overline{\text{WE}}$  being high on the positive edge of the clock. The bank must be active for at least  $t_{\text{RCD}}(\text{min})$  before the burst read command is issued. The first output appears in CAS latency number of clock cycles after the issue of burst read command. The burst length, burst sequence and latency from the burst read command is determined by the mode register which is already programmed. The burst read can be initiated on any column address of the active row.

The address wraps around if the initial address does not start from a boundary such that number of outputs from each I/O are equal to the burst length programmed in the mode register. The output goes into high-impedance at the end of the burst, unless a new burst read was initiated to keep the data output gapless. The burst read can be terminated by issuing another burst read or burst write in the same bank or the other active bank or a precharge command to the same bank. The burst stop command is valid at every page burst length.

### **BURST WRITE**

The burst write command is similar to burst read command and is used to write data into the SDRAM on consecutive clock cycles in adjacent addresses depending on burst length and burst sequence. By asserting low on  $\overline{\text{CS}}$ ,  $\overline{\text{CAS}}$  and  $\overline{\text{WE}}$  with valid column address, a write burst is initiated. The data inputs are provided for the initial address in the same clock cycle as the burst write command. The input buffer is deselected at the end of the burst length, even though the internal writing can be completed yet. The writing can be completed by issuing a burst read and DQM for blocking data inputs or burst write in the same or another active bank. The burst stop command is valid at every burst length. The write burst can also be terminated by using DQM for blocking data and precharging the bank  $t_{\text{RD}}(\text{min})$  after the last data input to be written into the active row. See DQM OPERATION also.

### **ALL BANKS PRECHARGE**

All banks can be precharged at the same time by using Precharge all command. Asserting low on  $\overline{\text{CS}}$ ,  $\overline{\text{RAS}}$ , and  $\overline{\text{WE}}$  with high on  $A_{10}/\text{AP}$  after all banks have satisfied  $t_{\text{RAS}}(\text{min})$  requirement, performs precharge on all banks. At the end of  $t_{\text{RP}}$  after performing precharge to all the banks, all banks are in idle state.

## D. DEVICE OPERATIONS (continued)

### PRECHARGE

The precharge operation is performed on an active bank by asserting low on  $\overline{CS}$ ,  $\overline{RAS}$ ,  $\overline{WE}$  and  $A_{10}/AP$  with valid  $BA_0 \sim BA_1$  of the bank to be precharged. The precharge command can be asserted anytime after  $t_{RAS(min)}$  is satisfied from the bank active command in the desired bank.  $t_{RP}$  is defined as the minimum number of clock cycles required to complete row precharge is calculated by dividing  $t_{RP}$  with clock cycle time and rounding up to the next higher integer. Care should be taken to make sure that burst write is completed or DQM is used to inhibit writing before precharge command is asserted. The maximum time any bank can be active is specified by  $t_{AS(max)}$ . Therefore, each bank activate command. At the end of precharge, the bank enters the idle state and is ready to be activated again. Entry to Power down, Auto refresh, Self refresh and Mode register set etc. is possible only when all banks are in idle state.

### AUTO PRECHARGE

The precharge operation can also be performed by using auto precharge. The SDRAM internally generates the timing to satisfy  $t_{RAS(min)}$  and "tRP" for the programmed burst length and  $\overline{CAS}$  latency. The auto precharge command is issued at the same time as burst read or burst write by asserting high on  $A_{10}/AP$ . If burst read or burst write by asserting high on  $A_{10}/AP$ , the bank is left active until a new command is asserted. Once auto precharge command is given, no new commands are possible to that particular bank until the bank achieves idle state.

### AUTO REFRESH

The storage cells of 64Mb, 128Mb and 256Mb SDRAM need to be refreshed every 64ms to maintain data. An auto refresh cycle accomplishes refresh of a single row of storage cells. The internal counter increments automatically on every auto refresh cycle to refresh all the rows. An auto refresh command is issued by asserting low on  $\overline{CS}$ ,  $\overline{RAS}$  and  $\overline{CAS}$  with high on  $CKE$  and  $\overline{WE}$ . The auto refresh command can only be asserted with both banks being in idle state and the device is not in power down mode ( $CKE$  is high in the previous cycle). The time required to complete the auto refresh operation is specified by  $t_{RC(min)}$ .

The minimum number of clock cycles required can be calculated by driving  $t_{RC}$  with clock cycle time and then rounding up to the next higher integer. The auto refresh command must be followed by NOP's until the auto refresh operation is completed. All banks will be in the idle state at the end of auto refresh operation. The auto refresh is the preferred refresh mode when the SDRAM is being used for normal data transactions. The 64Mb and 128Mb SDRAM's auto refresh cycle can be performed once in 15.6us or a burst of 4096 auto refresh cycles once in 64ms. The 256Mb SDRAM's auto refresh cycle can be performed once in 7.8us or a burst of 8192 auto refresh cycles once in 64ms.

### SELF REFRESH

The self refresh is another refresh mode available in the SDRAM. The self refresh is the preferred refresh mode for data retention and low power operation of SDRAM. In self refresh mode, the SDRAM disables the internal clock and all the input buffers except  $CKE$ . The refresh addressing and timing are internally generated to reduce power consumption.

The self refresh mode is entered from all banks idle state by asserting low on  $\overline{CS}$ ,  $\overline{RAS}$ ,  $\overline{CAS}$  and  $CKE$  with high on  $\overline{WE}$ . Once the self refresh mode is entered, only  $CKE$  state being low matters, all the other inputs including the clock are ignored in order to remain in the self refresh mode.

The self refresh is exited by restarting the external clock and then asserting high on  $CKE$ . This must be followed by NOP's for a minimum time of  $t_{RC}$  before the SDRAM reaches idle state to begin normal operation. If the system uses burst auto refresh during normal operation, it is recommended to use burst 8192 auto refresh cycles for 256Mb and burst 4096 auto refresh cycles for 128Mb and 64Mb immediately after exiting in self refresh mode.

## E. BASIC FEATURE AND FUNCTION DESCRIPTIONS

### 1. CLOCK Suspend

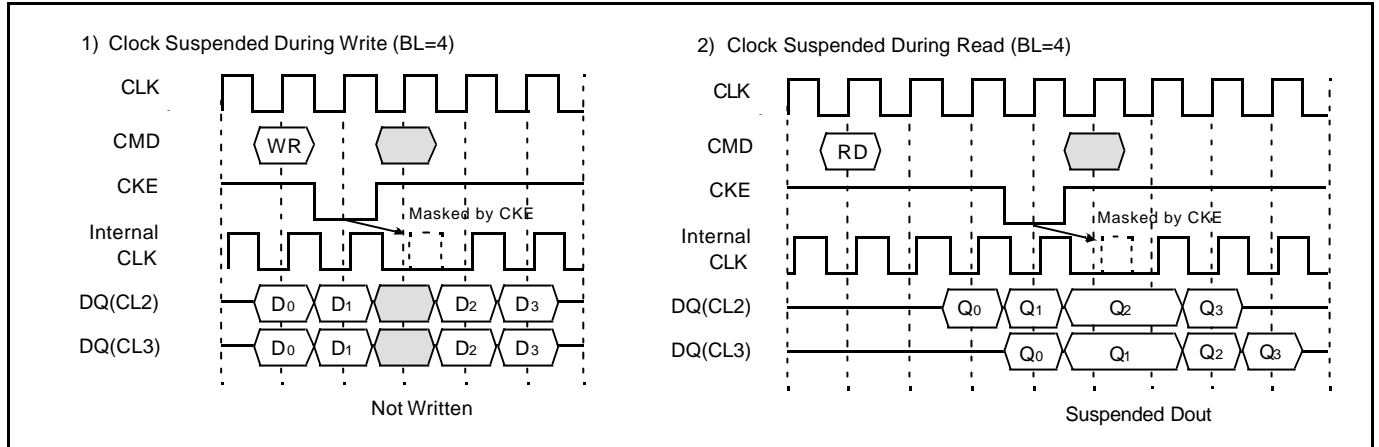

### 2. DQM Operation

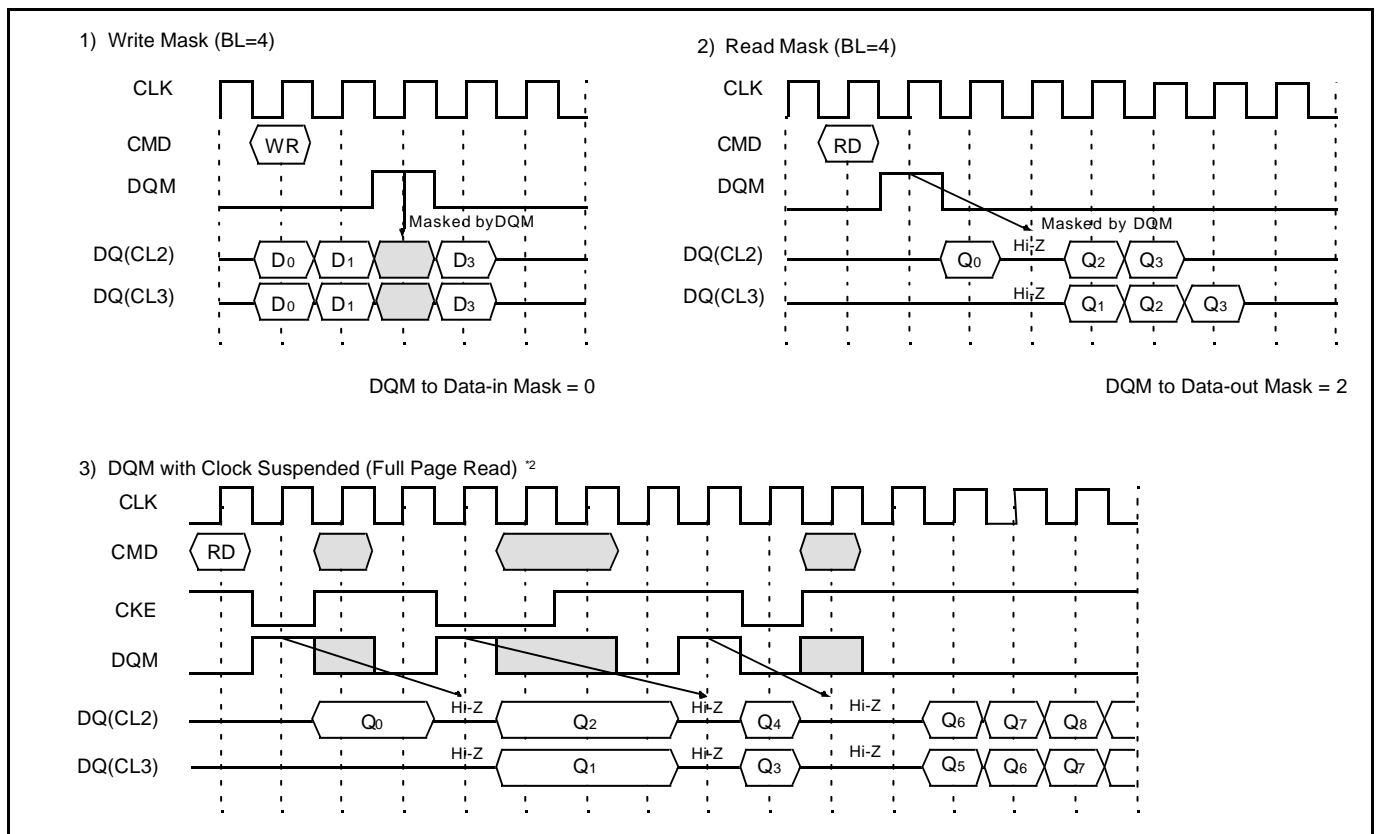

- \*Note : 1. CKE to CLK disable/enable = 1CLK.
- 2. DQM makes data out Hi-Z after 2CLKs which should be masked by CKE " L "
- 3. DQM masks both data-in and data-out.



3.  $\overline{\text{CAS}}$  Interrupt (I)

1) Read interrupted by Read (BL=4) \*1

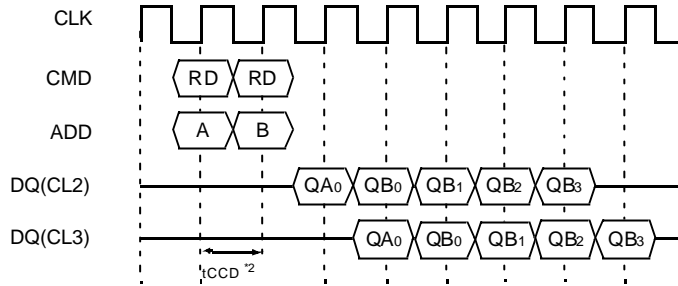

2) Write interrupted by Write (BL=2)

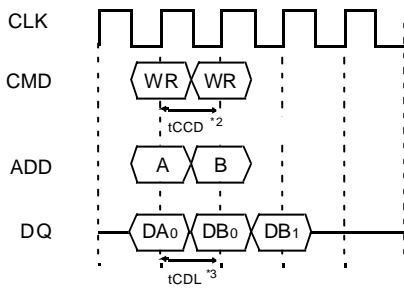

3) Write interrupted by Read (BL=2)

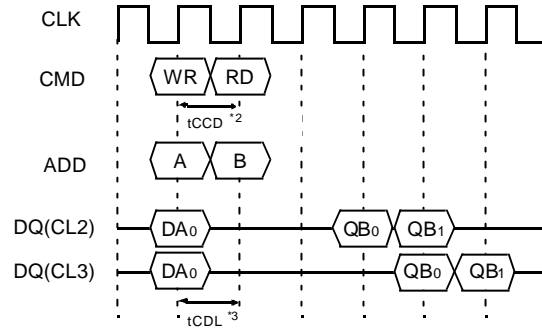

\*Note : 1. By "Interrupt", It is meant to stop burst read/write by external command before the end of burst.

By " $\overline{\text{CAS}}$  Interrupt", to stop burst read/write by  $\overline{\text{CAS}}$  access ; read and write.

2.  $t_{\text{CCD}}$  :  $\overline{\text{CAS}}$  to  $\overline{\text{CAS}}$  delay. (=1CLK)

3.  $t_{\text{CDL}}$  : Last data in to new column address delay. (=1CLK)

4.  $\overline{\text{CAS}}$  Interrupt (II) : Read Interrupted by Write & DQM

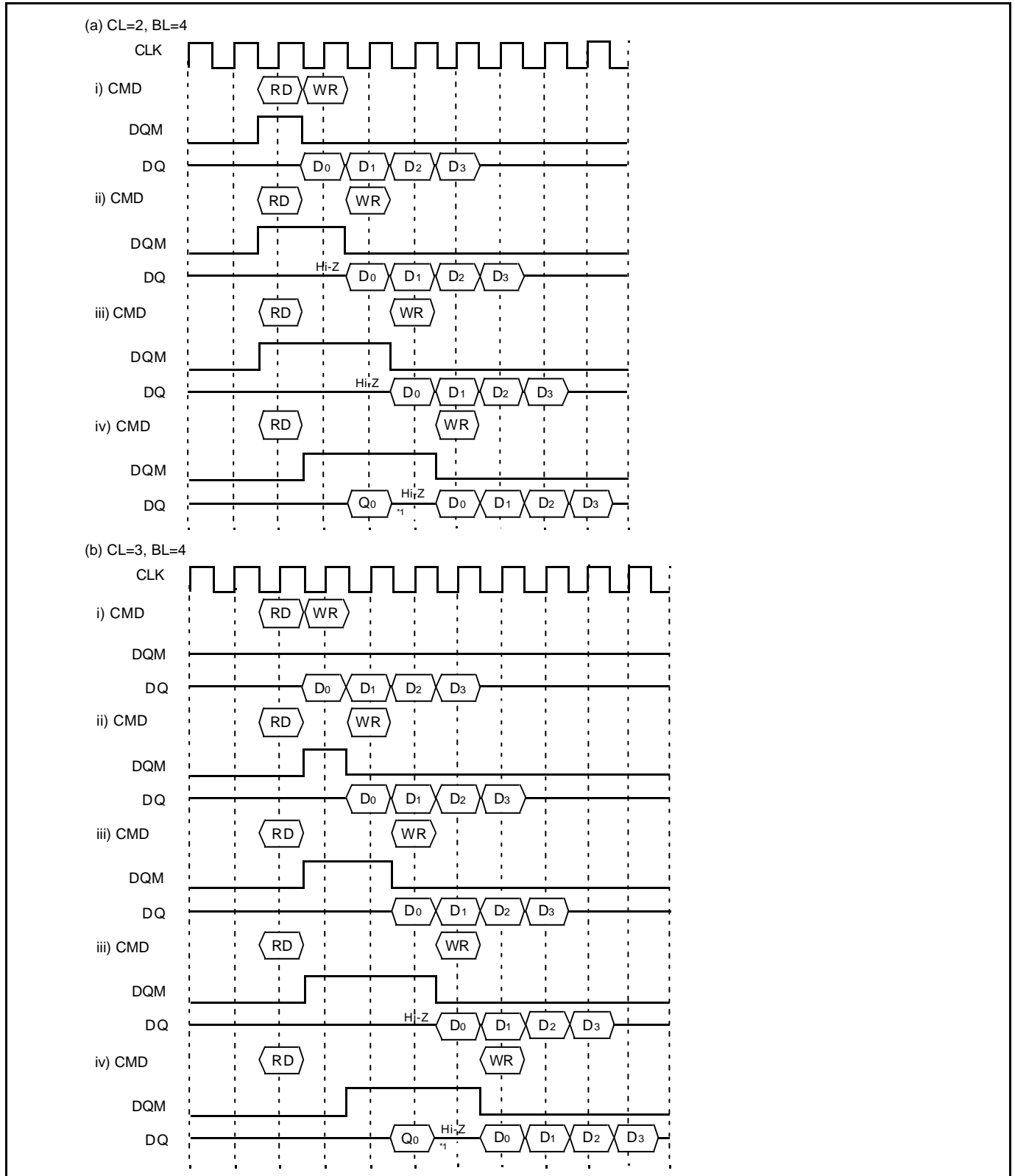

\*Note : 1. To prevent bus contention, there should be at least one gap between data in and data out.

## 5. Write Interrupted by Precharge & DQM

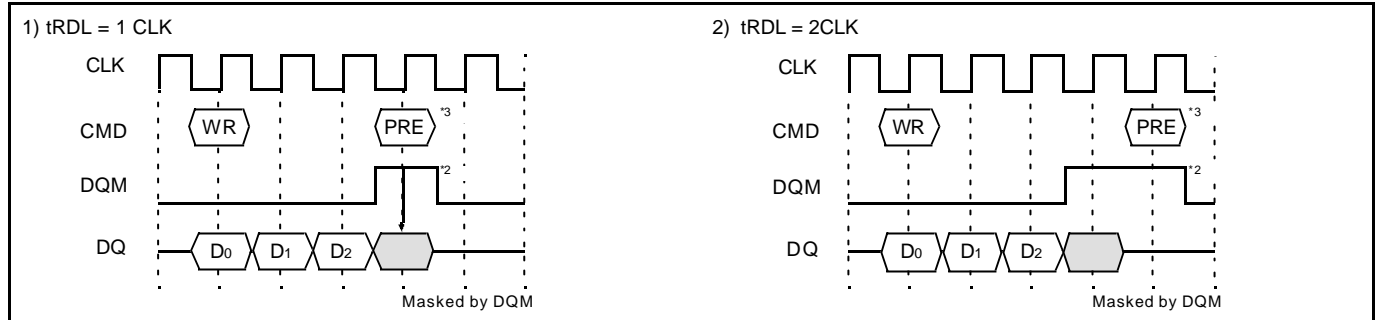

- \*Note :**
1. To prevent bus contention, DQM should be issued which makes at least one gap between data in and data out.
  2. To inhibit invalid write, DQM should be issued.
  3. This precharge command and burst write command should be of the same bank, otherwise it is not precharge interrupt but only another bank precharge of four banks operation.

## 6. Precharge

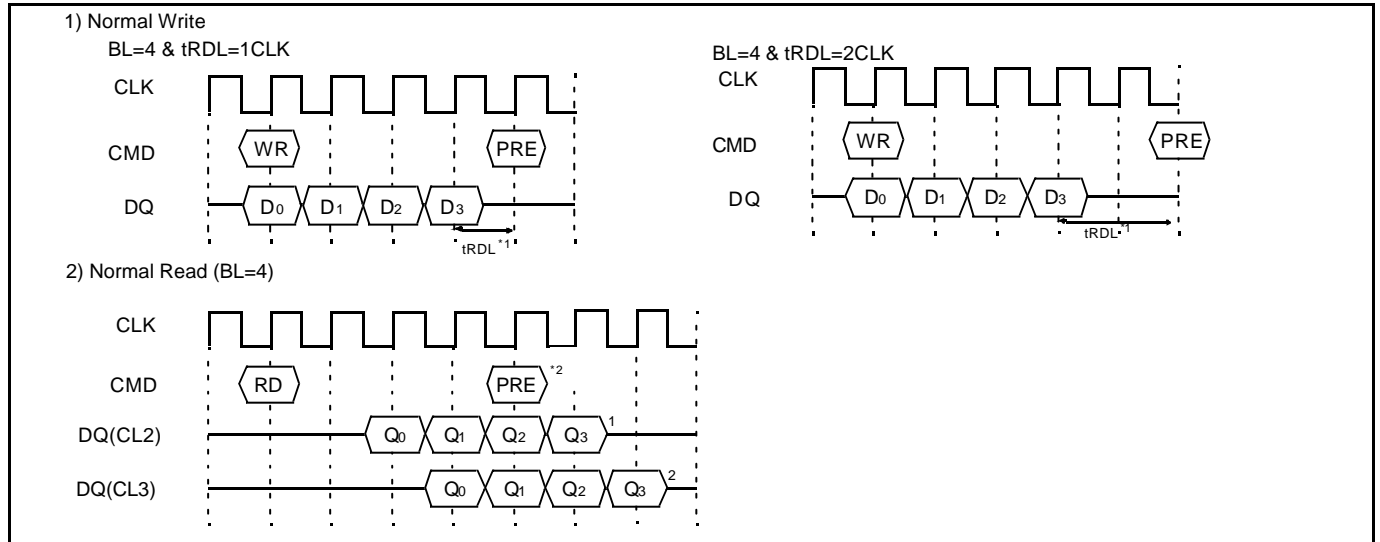

## 7. Auto Precharge

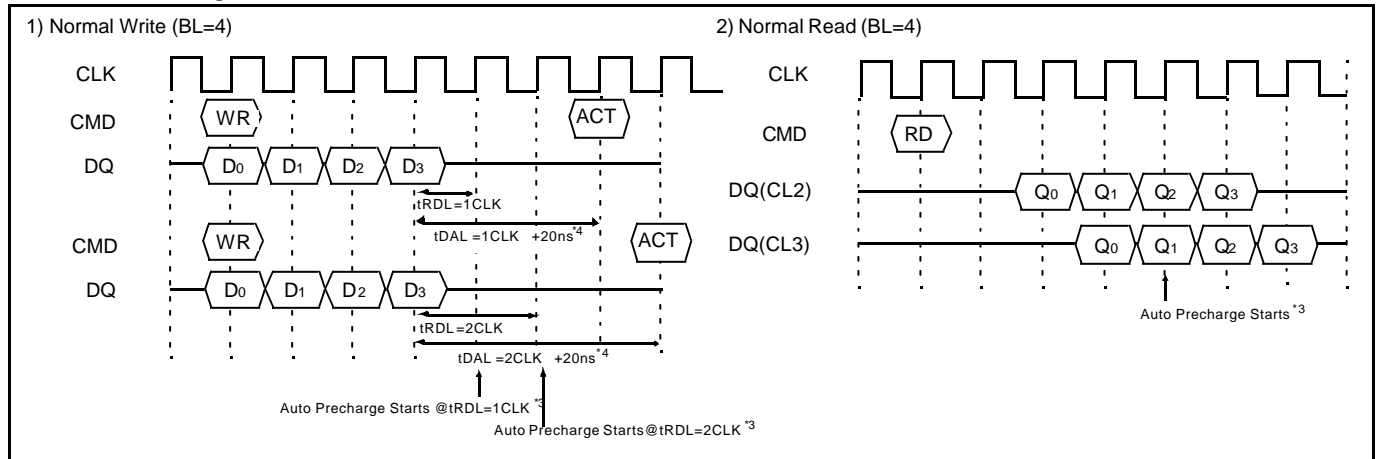

- \*Note :**
1. SAMSUNG can support  $t_{RDL}=1CLK$  and  $t_{RDL}=2CLK$  for all memory devices. SAMSUNG recommends  $t_{RDL}=2 CLK$ .
  2. Number of valid output data after row precharge : 1, 2 for CAS Latency = 2, 3 respectively.
  3. The row active command of the precharge bank can be issued after  $t_{RP}$  from this point. The new read/write command of other activated bank can be issued from this point. At burst read/write with auto precharge, CAS interrupt of the same bank is illegal
  4. tDAL defined Last data in to Active delay. SAMSUNG can support  $t_{DAL}=1CLK+20ns$  and  $2CLK+20ns$  ,recommends  $t_{DAL}=2CLK+20ns$ .

## 8. Burst Stop & Interrupted by Precharge

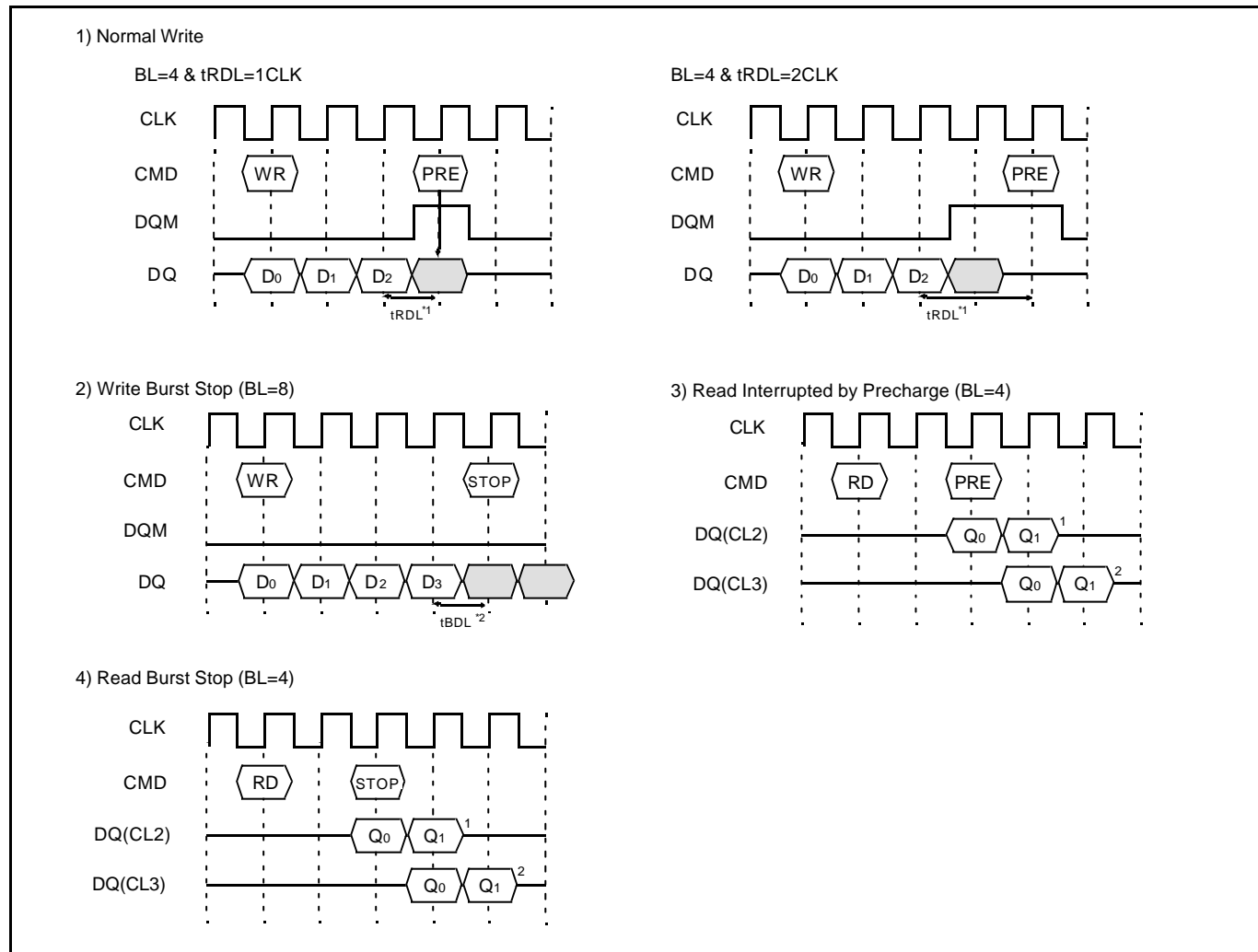

## 9. MRS

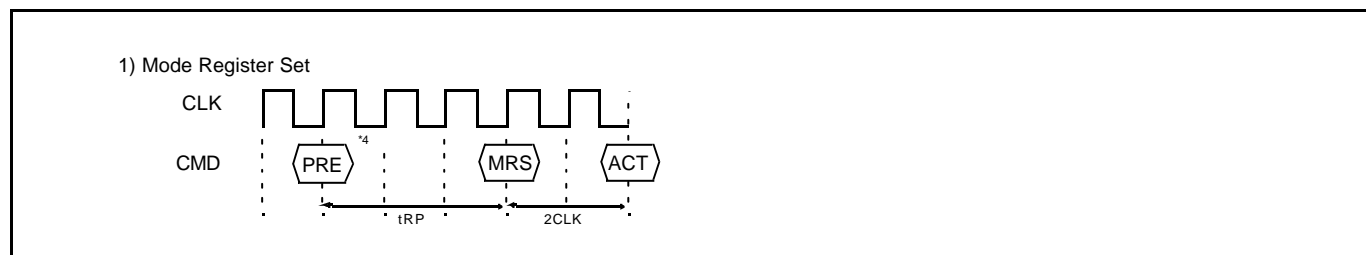

**\*Note :** 1. SAMSUNG can support tRDL=1CLK and tRDL=2CLK for all memory devices. SAMSUNG recommends tRDL=2 CLK.

2. tBDL : 1 CLK ; Last data in to burst stop delay.

Read or write burst stop command is valid at every burst length.

3. Number of valid output data after row precharge or burst stop : 1, 2 for CAS latency= 2, 3 respectively.

4. PRE : All banks precharge is necessary.

MRS can be issued only at all banks precharge state.

## 10. Clock Suspend Exit & Power Down Exit

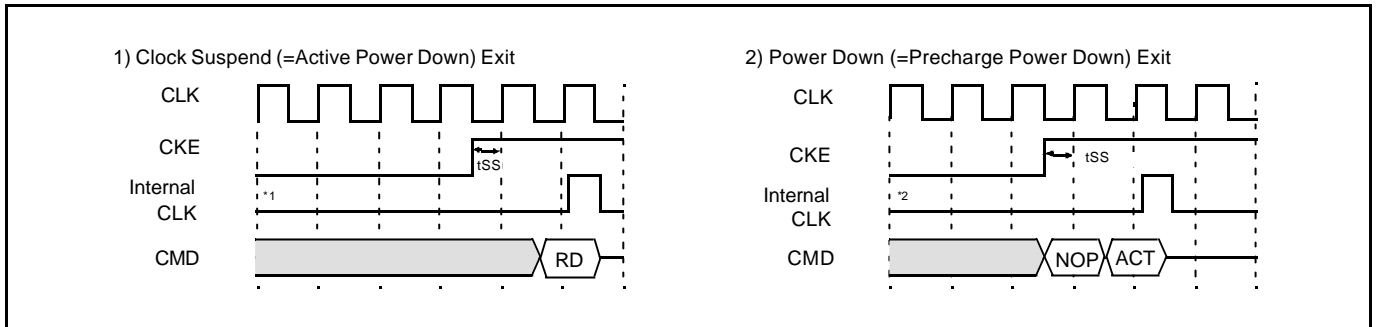

## 11. Auto Refresh & Self Refresh

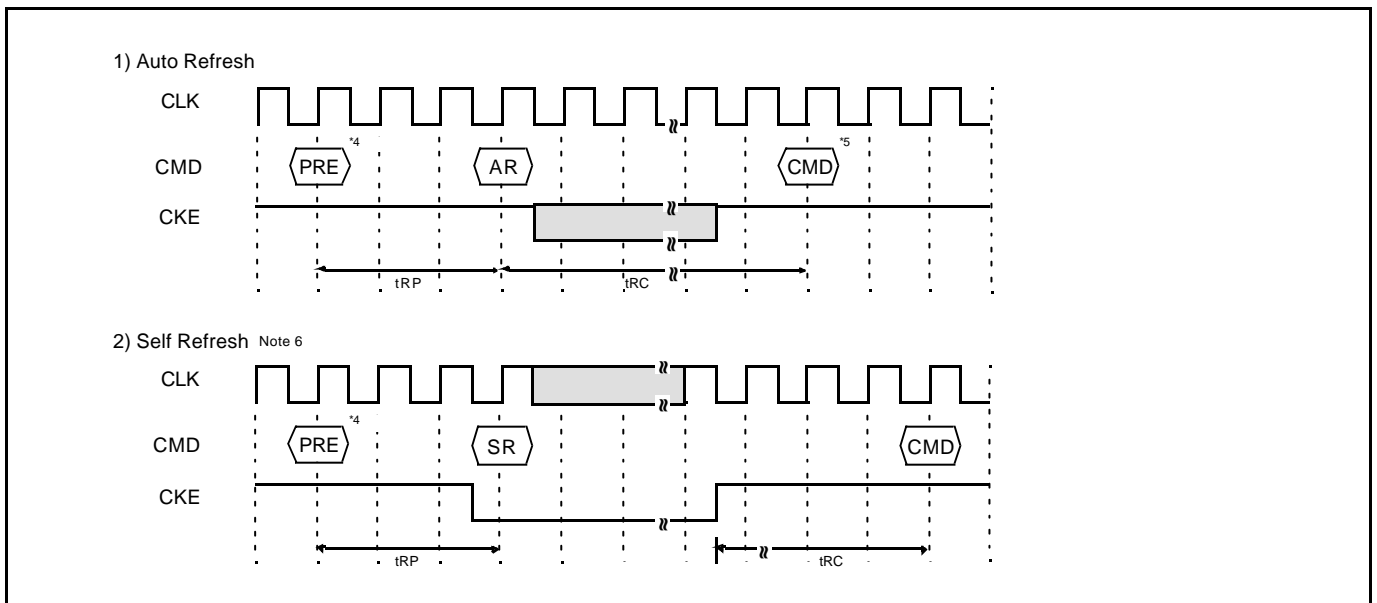

**\*Note :** 1. Active power down : one or more banks active state.

2. Precharge power down : all banks precharge state.

3. The auto refresh is the same as CBR refresh of conventional DRAM.

No precharge commands are required after auto refresh command.

During  $t_{RC}$  from auto refresh command, any other command can not be accepted.

4. Before executing auto/self refresh command, all banks must be idle state.

5. MRS, Bank Active, Auto/Self Refresh, Power Down Mode Entry.

6. During self refresh mode, refresh interval and refresh operation are performed internally.

After self refresh entry, self refresh mode is kept while CKE is low.

During self refresh mode, all inputs except CKE will be don't cared, and outputs will be in Hi-Z state.

For the time interval of  $t_{RC}$  from self refresh exit command, any other command can not be accepted.

Before/After self refresh mode, burst auto refresh cycle (4096 cycles for 64Mb & 128Mb, 8192 cycles for 256Mb) is recommended.

## 12. About Burst Type Control

Basic MODE	Sequential Counting	At MRS A <sub>3</sub> = "0". See the BURST SEQUENCE TABLE. (BL=4, 8) BL=1, 2, 4, 8 and full page.
	Interleave Counting	At MRS A <sub>3</sub> = "1". See the BURST SEQUENCE TABLE. (BL=4, 8) BL=4, 8. At BL=1, 2 Interleave Counting = Sequential Counting
Random MODE	Random column Access t <sub>CCD</sub> = 1 CLK	Every cycle Read/Write Command with random column address can realize Random Column Access. That is similar to Extended Data Out (EDO) Operation of conventional DRAM.

## 13. About Burst Length Control

Basic MODE	1	At MRS A <sub>2,1,0</sub> = "000". At auto precharge, t <sub>RAS</sub> should not be violated.
	2	At MRS A <sub>2,1,0</sub> = "001". At auto precharge, t <sub>RAS</sub> should not be violated.
	4	At MRS A <sub>2,1,0</sub> = "010".
	8	At MRS A <sub>2,1,0</sub> = "011".
	Full Page	At MRS A <sub>2,1,0</sub> = "111". Wrap around mode(infinite burst length) should be stopped by burst stop. R <sub>AS</sub> interrupt or C <sub>AS</sub> interrupt
Special MODE	BRSW	At MRS A <sub>9</sub> = "1". Read burst =1, 2, 4, 8, full page write Burst =1 At auto precharge of write, t <sub>RAS</sub> should not be violated.
Random MODE	Burst Stop	t <sub>BDL</sub> = 1, Valid DQ after burst stop is 1, 2 for CAS latency 2, 3 respectively Using burst stop command, any burst length control is possible.
Interrupt MODE	R <sub>AS</sub> Interrupt (Interrupted by Precharge)	Before the end of burst, Row precharge command of the same bank stops read/write burst with Row precharge. t <sub>RDL</sub> = 2 with DQM, valid DQ after burst stop is 1, 2 for CAS latency 2, 3 respectively. During read/write burst with auto precharge, R <sub>AS</sub> interrupt can not be issued.
	C <sub>AS</sub> Interrupt	Before the end of burst, new read/write stops read/write burst and starts new read/write burst. During read/write burst with auto precharge, C <sub>AS</sub> interrupt can not be issued.

# DEVICE OPERATIONS

# CMOS SDRAM

FUNCTION TRUTH TABLE (TABLE 1)

Current State	$\overline{CS}$	$\overline{RAS}$	$\overline{CAS}$	$\overline{WE}$	BA	ADDR	ACTION	Note
IDLE	H	X	X	X	X	X	NOP	
	L	H	H	H	X	X	NOP	
	L	H	H	L	X	X	ILLEGAL	2
	L	H	L	X	BA	CA, A <sub>10</sub> /AP	ILLEGAL	2
	L	L	H	H	BA	RA	Row (& Bank) Active ; Latch RA	
	L	L	H	L	BA	A <sub>10</sub> /AP	NOP	4
	L	L	L	H	X	X	Auto Refresh or Self Refresh	5
Row Active	L	L	L	L	OP code	OP code	Mode Register Access	5
	H	X	X	X	X	X	NOP	
	L	H	H	H	X	X	NOP	
	L	H	H	L	X	X	ILLEGAL	2
	L	H	L	H	BA	CA, A <sub>10</sub> /AP	Begin Read ; latch CA ; determine AP	
	L	H	L	L	BA	CA, A <sub>10</sub> /AP	Begin Write ; latch CA ; determine AP	
	L	L	H	H	BA	RA	ILLEGAL	2
Read	L	L	H	L	BA	A <sub>10</sub> /AP	Precharge	
	L	L	L	X	X	X	ILLEGAL	
	H	X	X	X	X	X	NOP (Continue Burst to End --> Row Active)	
	L	H	H	H	X	X	NOP (Continue Burst to End --> Row Active)	
	L	H	H	L	X	X	Term burst --> Row active	
	L	H	L	H	BA	CA, A <sub>10</sub> /AP	Term burst, New Read, Determine AP	
	L	H	L	L	BA	CA, A <sub>10</sub> /AP	Term burst, New Write, Determine AP	3
Write	L	L	H	H	BA	RA	ILLEGAL	2
	L	L	H	L	BA	A <sub>10</sub> /AP	Term burst, Precharge timing for Reads	
	L	L	L	X	X	X	ILLEGAL	
	H	X	X	X	X	X	NOP (Continue Burst to End --> Row Active)	
	L	H	H	H	X	X	NOP (Continue Burst to End --> Row Active)	
	L	H	H	L	X	X	Term burst --> Row active	
	L	H	L	H	BA	CA, A <sub>10</sub> /AP	Term burst, New read, Determine AP	3
Read with Auto Precharge	L	H	L	L	BA	CA, A <sub>10</sub> /AP	Term burst, New Write, Determine AP	3
	L	L	H	H	BA	RA	ILLEGAL	2
	L	L	H	L	BA	A <sub>10</sub> /AP	Term burst, precharge timing for Writes	3
	L	L	L	X	X	X	ILLEGAL	
	H	X	X	X	X	X	NOP (Continue Burst to End --> Precharge)	
	L	H	H	H	X	X	NOP (Continue Burst to End --> Precharge)	
	L	H	H	L	X	X	ILLEGAL	
Write with Auto Precharge	L	H	L	X	BA	CA, A <sub>10</sub> /AP	ILLEGAL	
	L	L	H	X	BA	RA, RA <sub>10</sub>	ILLEGAL	2
	L	L	L	X	X	X	ILLEGAL	
	H	X	X	X	X	X	NOP --> Idle after t <sub>RP</sub>	
	L	H	H	H	X	X	NOP --> Idle after t <sub>RP</sub>	
	L	H	H	L	X	X	ILLEGAL	2
Pre-charging	L	H	L	X	BA	CA	ILLEGAL	2
	L	L	H	H	BA	RA	ILLEGAL	2
	L	L	H	L	BA	A <sub>10</sub> /AP	NOP --> Idle after t <sub>RP</sub>	4

**FUNCTION TRUTH TABLE (TABLE 1)**

Current State	$\overline{CS}$	$\overline{RAS}$	$\overline{CAS}$	$\overline{WE}$	BA	ADDR	ACTION	Note
Row Activating	L	L	L	X	X	X	ILLEGAL	
	H	X	X	X	X	X	NOP --> Row Active after $t_{RC}$	
	L	H	H	H	X	X	NOP --> Row Active after $t_{RC}$	
	L	H	H	L	X	X	ILLEGAL	2
	L	H	L	X	BA	CA	ILLEGAL	2
	L	L	H	H	BA	RA	ILLEGAL	2
	L	L	H	L	BA	A <sub>10</sub> /AP	ILLEGAL	2
Refreshing	L	L	L	X	X	X	ILLEGAL	
	H	X	X	X	X	X	NOP --> Idle after $t_{RC}$	
	L	H	H	X	X	X	NOP --> Idle after $t_{RC}$	
	L	H	L	X	X	X	ILLEGAL	
	L	L	H	X	X	X	ILLEGAL	
Mode Register Accessing	L	L	L	X	X	X	ILLEGAL	
	H	X	X	X	X	X	NOP --> Idle after 2 clocks	
	L	H	H	H	X	X	NOP --> Idle after 2 clocks	
	L	H	H	L	X	X	ILLEGAL	
	L	H	L	X	X	X	ILLEGAL	
L	L	X	X	X	X	ILLEGAL		

Abbreviations : RA = Row Address      BA = Bank Address  
 NOP = No Operation Command      CA = Column Address      AP = Auto Precharge

- \*Note :**
1. All entries assume the CKE was active (High) during the precharge clock and the current clock cycle.
  2. Illegal to bank in specified state ; Function may be legal in the bank indicated by BA, depending on the state of that bank.
  3. Must satisfy bus contention, bus turn around, and/or write recovery requirements.
  4. NOP to bank precharging or in idle state. May precharge bank indicated by BA (and A<sub>10</sub>/AP).
  5. Illegal if any bank is not idle.



## FUNCTION TRUTH TABLE (TABLE 2)

Current State	CKE (n-1)	CKE n	$\overline{CS}$	$\overline{RAS}$	$\overline{CAS}$	$\overline{WE}$	ADDR	ACTION	Note
Self Refresh	H	X	X	X	X	X	X	INVALID	
	L	H	H	X	X	X	X	Exit Self Refresh --> Idle after $t_{RFC}$ (ABI)	6
	L	H	L	H	H	H	X	Exit Self Refresh --> Idle after $t_{RFC}$ (ABI)	6
	L	H	L	H	H	L	X	ILLEGAL	
	L	H	L	H	L	X	X	ILLEGAL	
	L	H	L	L	X	X	X	ILLEGAL	
All Banks Precharge Power Down	L	L	X	X	X	X	X	NOP (Maintain Self Refresh)	
	H	X	X	X	X	X	X	INVALID	
	L	H	H	X	X	X	X	Exit Power Down --> ABI	
	L	H	L	H	H	H	X	Exit Power Down --> ABI	7
	L	H	L	H	H	L	X	ILLEGAL	7
	L	H	L	H	L	X	X	ILLEGAL	
All Banks Idle	L	L	X	X	X	X	X	NOP (Maintain Low Power Mode)	
	H	H	X	X	X	X	X	Refer to Table 1	
	H	L	H	X	X	X	X	Enter Power Down	
	H	L	L	H	H	H	X	Enter Power Down	8
	H	L	L	H	H	L	X	ILLEGAL	8
	H	L	L	H	L	X	X	ILLEGAL	
	H	L	L	L	H	H	RA	Row (& Bank) Active	
	H	L	L	L	L	H	X	Enter Self Refresh	8
	H	L	L	L	L	L	OP Code	Mode Register Access	
Any State other than Listed above	L	L	X	X	X	X	X	NOP	
	H	H	X	X	X	X	X	Refer to Operations in Table 1	
	H	L	X	X	X	X	X	Begin Clock Suspend next cycle	9
	L	H	X	X	X	X	X	Exit Clock Suspend next cycle	9
L	L	X	X	X	X	X	Maintain Clock Suspend		

Abbreviations : ABI = All Banks Idle, RA = Row Address

**\*Note :** 6. CKE low to high transition is asynchronous.

7. CKE low to high transition is asynchronous if restarts internal clock.

A minimum setup time  $1\text{CLK} + t_{ss}$  must be satisfied before any command other than exit.

8. Power down and self refresh can be entered only from the both banks idle state.

9. Must be a legal command.

Single Bit Read - Write - Read Cycle(Same Page) @CAS Latency=3, Burst Length=1

Power Up Sequence

Read & Write Cycle at Same Bank @Burst Length=4, tRDL=1CLK

Read & Write Cycle at Same Bank @Burst Length=4, tRDL=2CLK

Page Read & Write Cycle at Same Bank @Burst Length=4, tRDL=1CLK

Page Read & Write Cycle at Same Bank @Burst Length=4, tRDL=2CLK

Page Read Cycle at Different Bank @Burst Length=4

Page Write Cycle at Different Bank @Burst Length=4, tRDL=1CLK

Page Write Cycle at Different Bank @Burst Length=4, tRDL=2CLK

Read & Write Cycle at Different Bank @Burst Length=4

Read & Write Cycle With Auto Precharge I @Burst Length=4

Read & Write Cycle With Auto Precharge II @Burst Length=4

Clock Suspension & DQM Operation Cycle @CAS Latency=2, Burst Length=4

Read Interrupted by Precharge Command & Read Burst Stop Cycle @ Full Page Burst

Write Interrupted by Precharge Command & Write Burst Stop Cycle @ Full Page Burst, tRDL=1CLK

Write Interrupted by Precharge Command & Write Burst Stop Cycle @ Full Page Burst, tRDL=2CLK

Burst Read Single bit Write Cycle @Burst Length =2

Active/precharge Power Dower Down Mode @CAS Latency=2 Burst Length=4

Self Refresh Entry & Exit Cycle

Mode Register Set Cycle

Auto Refresh Cycle

# TIMING DIAGRAM

# CMOS SDRAM

Single Bit Read-Write-Read Cycle(Same Page) @CAS Latency=3, Burst Length=1

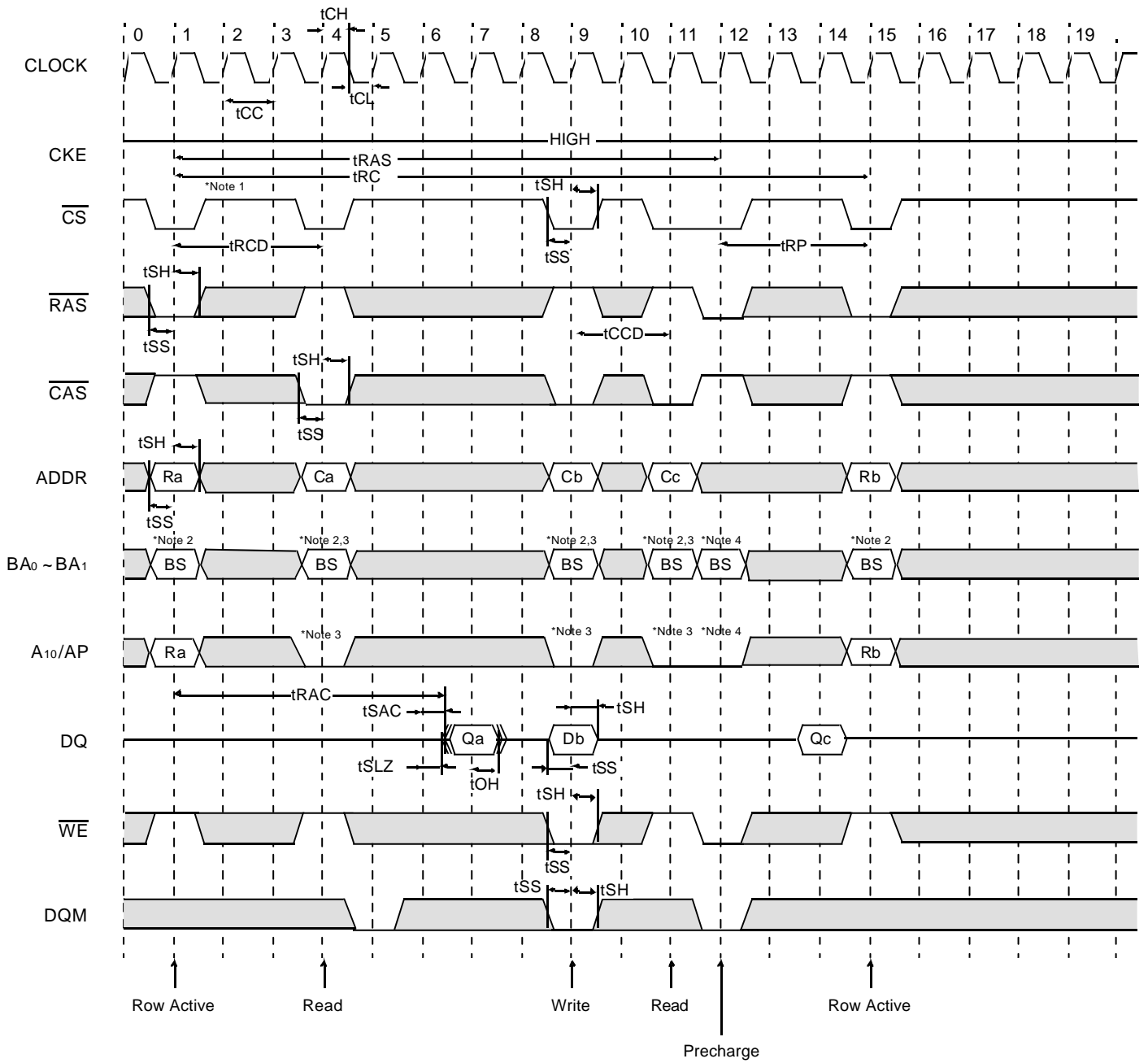

□ : Don't care



# TIMING DIAGRAM

# CMOS SDRAM

**\*Note :**

1. All input except CKE & DQM can be don't care when  $\overline{CS}$  is high at the CLK high going edge.
2. Bank active & read/write are controlled by BA0-BA1.

64Mb/128Mb		256Mb		Active & Read/Write
BA0	BA1	BA0	BA1	
0	0	0	0	Bank A
0	1	1	0	Bank B
1	0	0	1	Bank C
1	1	1	1	Bank D

3. Enable and disable auto precharge function are controlled by A10/AP in read/write command

A10/AP	64Mb/128Mb		256Mb		Operation
	BA0	BA1	BA0	BA1	
0	0	0	0	0	Disable auto precharge, leave bank A active at end of burst.
	0	1	1	0	Disable auto precharge, leave bank B active at end of burst.
	1	0	0	1	Disable auto precharge, leave bank C active at end of burst.
	1	1	1	1	Disable auto precharge, leave bank D active at end of burst.
1	0	0	0	0	Enable auto precharge, precharge bank A at end of burst.
	0	1	1	0	Enable auto precharge, precharge bank B at end of burst.
	1	0	0	1	Enable auto precharge, precharge bank C at end of burst.
	1	1	1	1	Enable auto precharge, precharge bank D at end of burst.

4. A10/AP and BA0-BA1 control bank precharge when precharge command is asserted.

A10/AP	64Mb/128Mb		256Mb		Precharge
	BA0	BA1	BA0	BA1	
0	0	0	0	0	Bank A
0	0	1	1	0	Bank B
0	1	0	0	1	Bank C
0	1	1	1	1	Bank D
1	x	x	x	x	All Banks

# TIMING DIAGRAM

# CMOS SDRAM

## Power Up Sequence

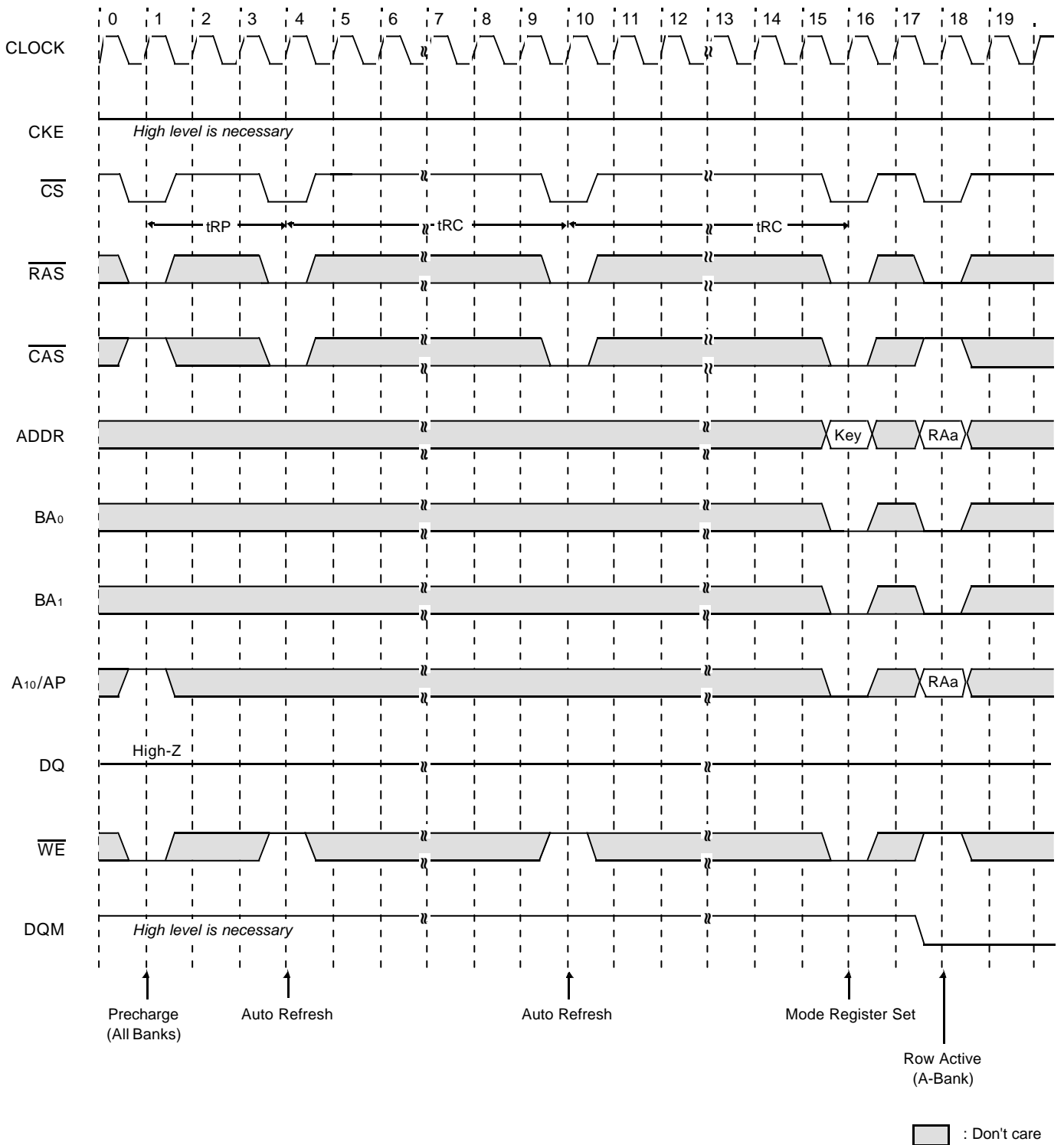

# TIMING DIAGRAM

# CMOS SDRAM

Read & Write Cycle at Same Bank @Burst Length=4, tRDL=1CLK

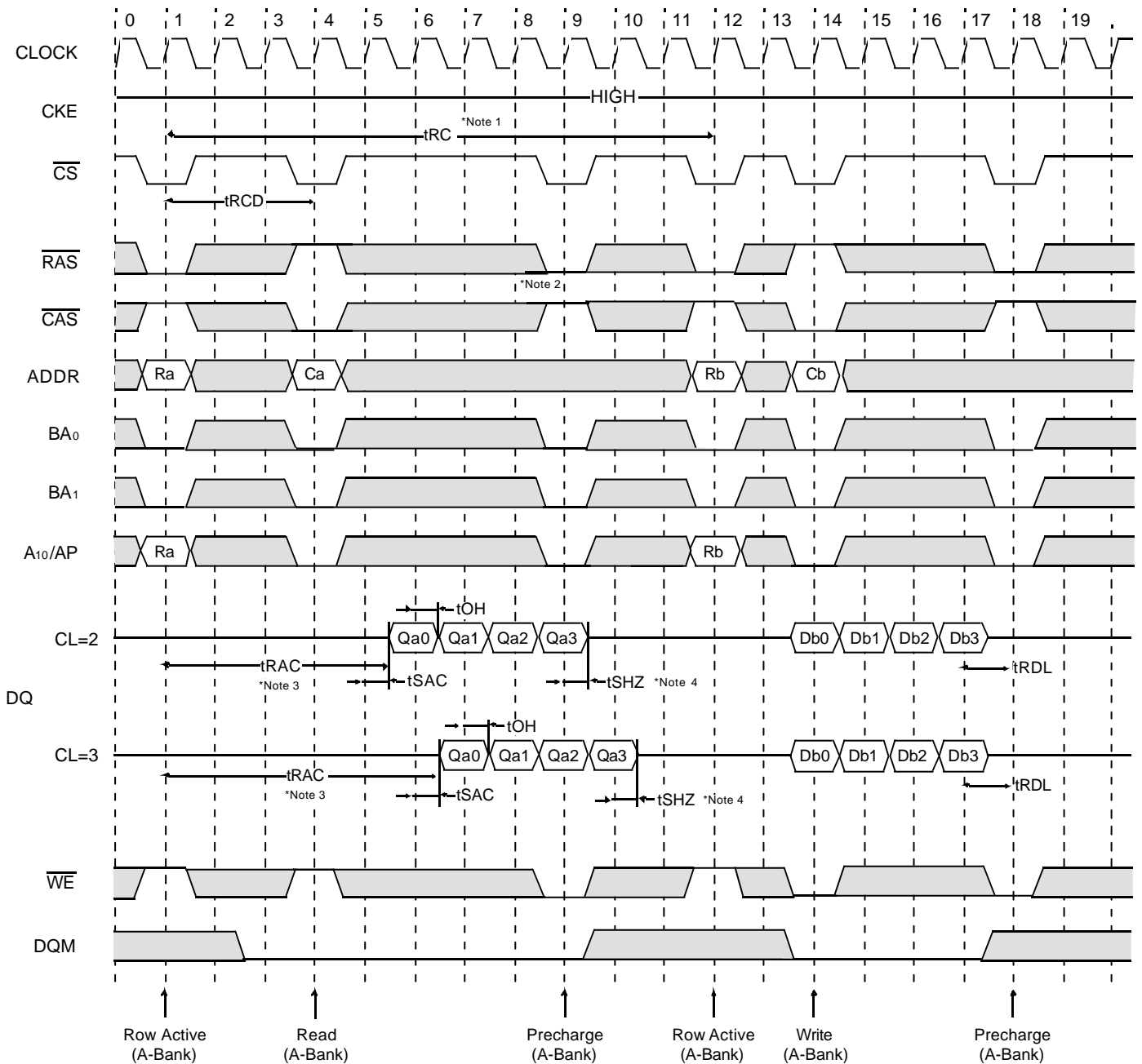

□ : Don't care

- \*Note :**
1. Minimum row cycle times is required to complete internal DRAM operation.
  2. Row precharge can interrupt burst on any cycle. [CAS Latency - 1] number of valid output data is available after Row precharge. Last valid output will be Hi-Z (tSHZ) after the clock.
  3. Access time from Row active command. tCC = (tRCD + CAS latency - 1) + tSAC
  4. Output will be Hi-Z after the end of burst. (1, 2, 4, 8 & Full page bit burst)



ELECTRONICS

# TIMING DIAGRAM

# CMOS SDRAM

Read & Write Cycle at Same Bank @Burst Length=4,  $t_{RDL}=2CLK$

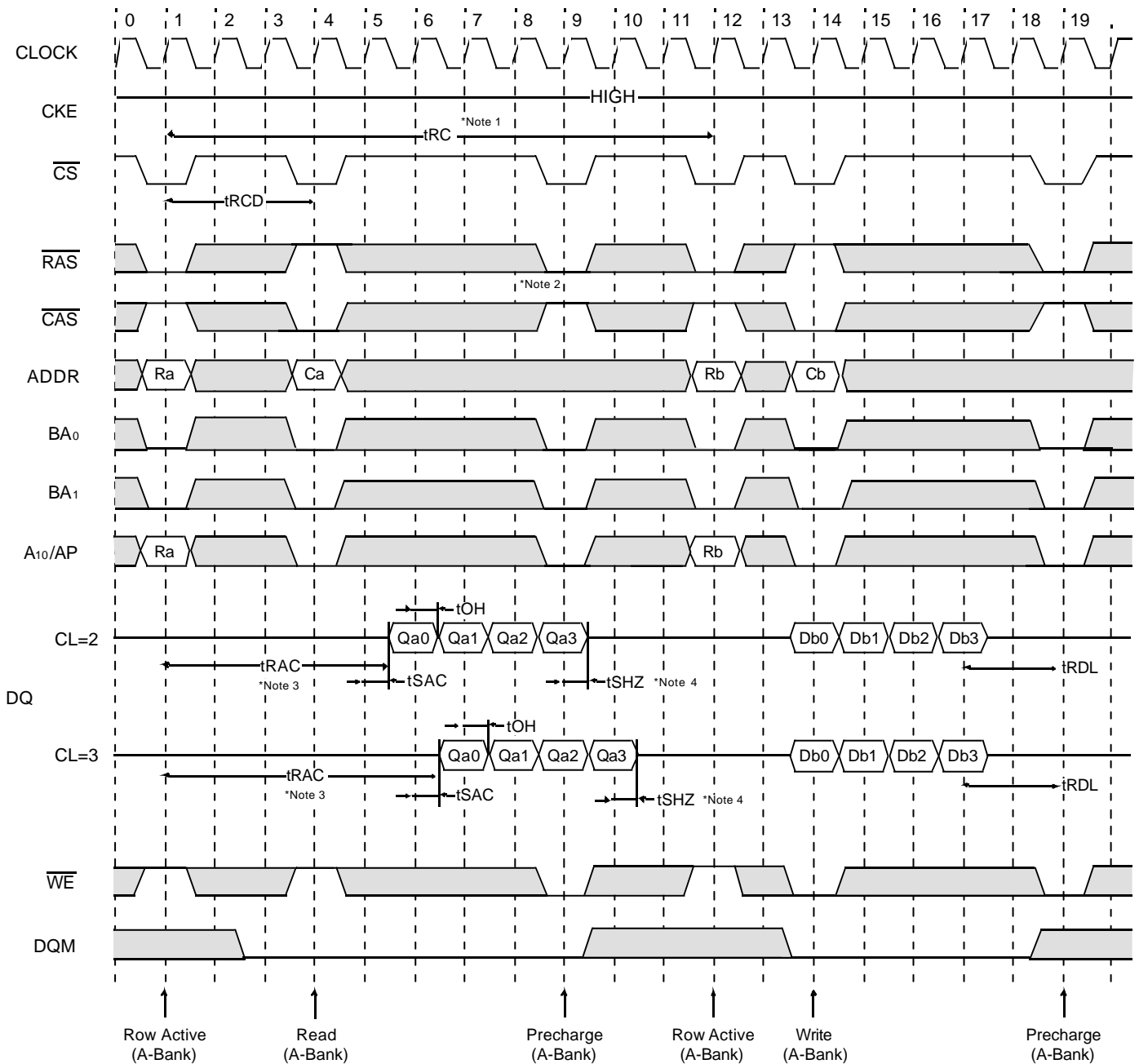

□ : Don't care

- \*Note :**
1. Minimum row cycle times is required to complete internal DRAM operation.
  2. Row precharge can interrupt burst on any cycle. [CAS Latency - 1] number of valid output data is available after Row precharge. Last valid output will be Hi-Z( $t_{SHZ}$ ) after the clock.
  3. Access time from Row active command.  $t_{CC} = (t_{RCD} + CAS\ latency - 1) + t_{SAC}$
  4. Output will be Hi-Z after the end of burst. (1, 2, 4, 8 & Full page bit burst)



ELECTRONICS

# TIMING DIAGRAM

# CMOS SDRAM

## Page Read & Write Cycle at Same Bank @Burst Length=4, tRDL=1CLK

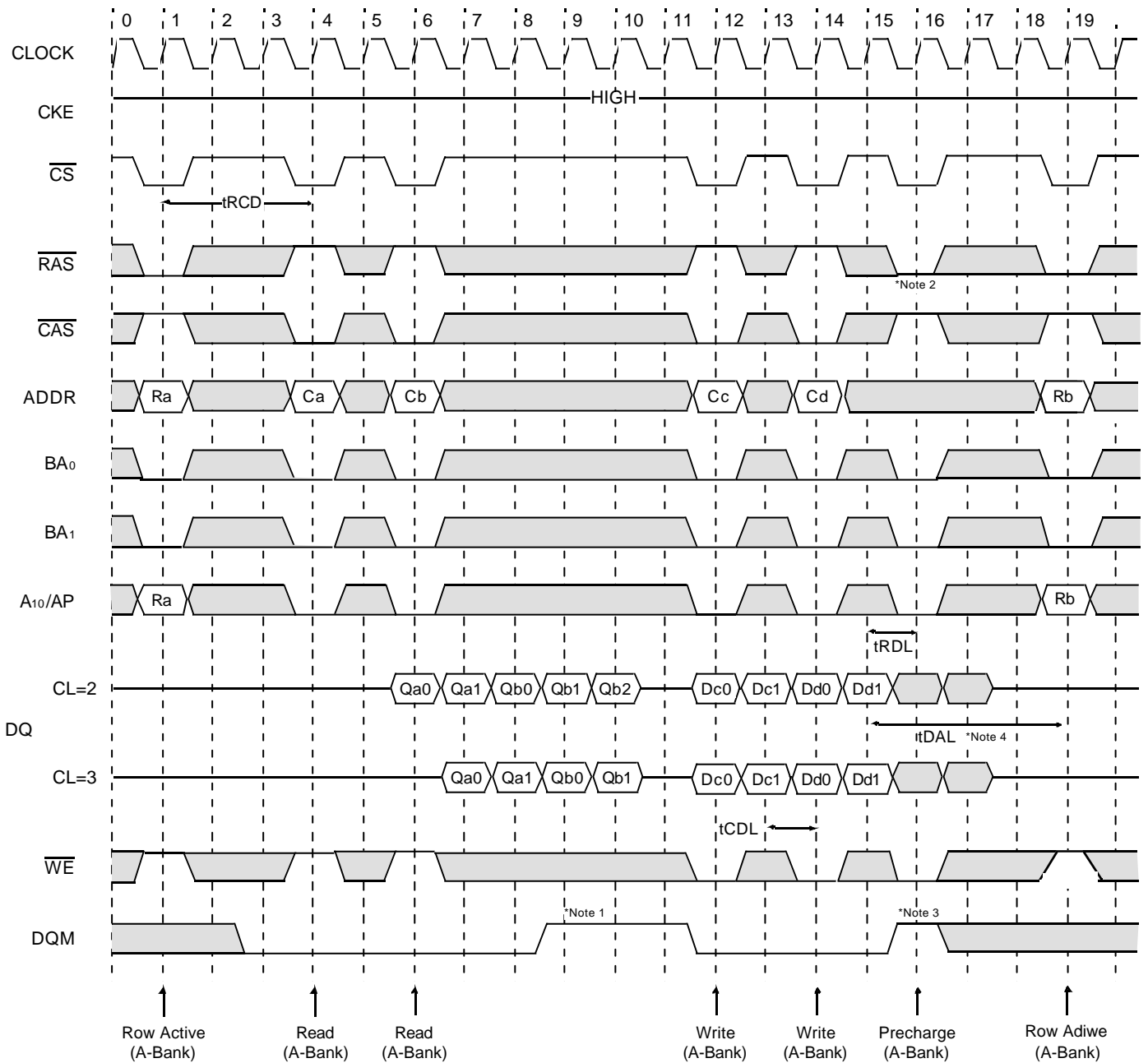

- \*Note :**
1. To write data before burst read ends, DQM should be asserted three cycle prior to write command to avoid bus contention.
  2. Row precharge will interrupt writing. Last data input,  $t_{RDL}$  before Row precharge, will be written.
  3. DQM should mask invalid input data on precharge command cycle when asserting precharge before end of burst. Input data after Row precharge cycle will be masked internally.
  4.  $t_{DAL}$ , last data in to active delay, is  $1CLK + 20ns$





# TIMING DIAGRAM

# CMOS SDRAM

## Page Read & Write Cycle at Same Bank @Burst Length=4, tRDL=2CLK

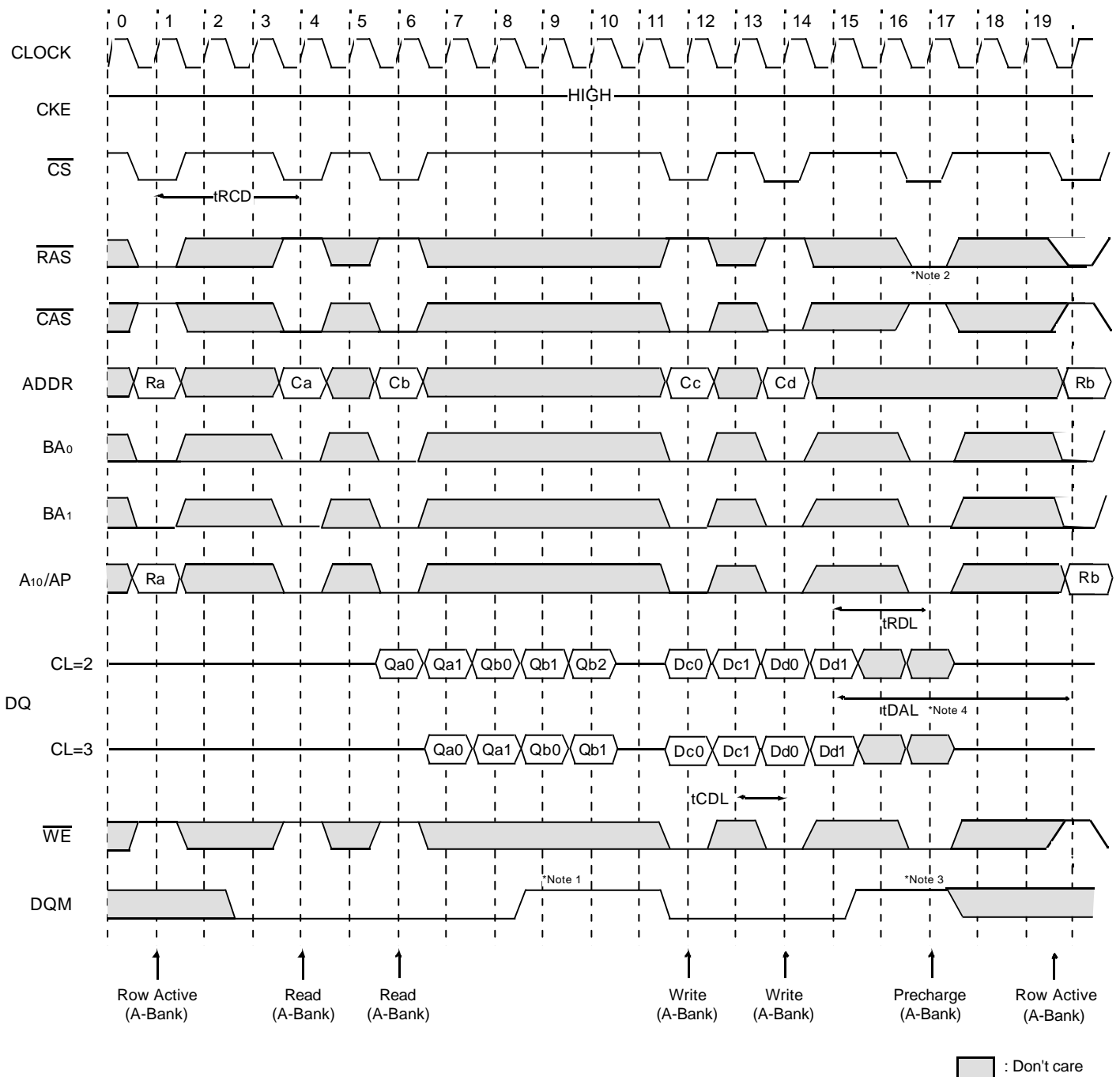

- \*Note :**
1. To write data before burst read ends, DQM should be asserted three cycle prior to write command to avoid bus contention.
  2. Row precharge will interrupt writing. Last data input, tRDL before Row precharge, will be written.
  3. DQM should mask invalid input data on precharge command cycle when asserting precharge before end of burst. Input data after Row precharge cycle will be masked internally.
  4. tDAL ,last data in to active delay, is 2CLK + 20ns.



# TIMING DIAGRAM

# CMOS SDRAM

## Page Read Cycle at Different Bank @Burst Length=4

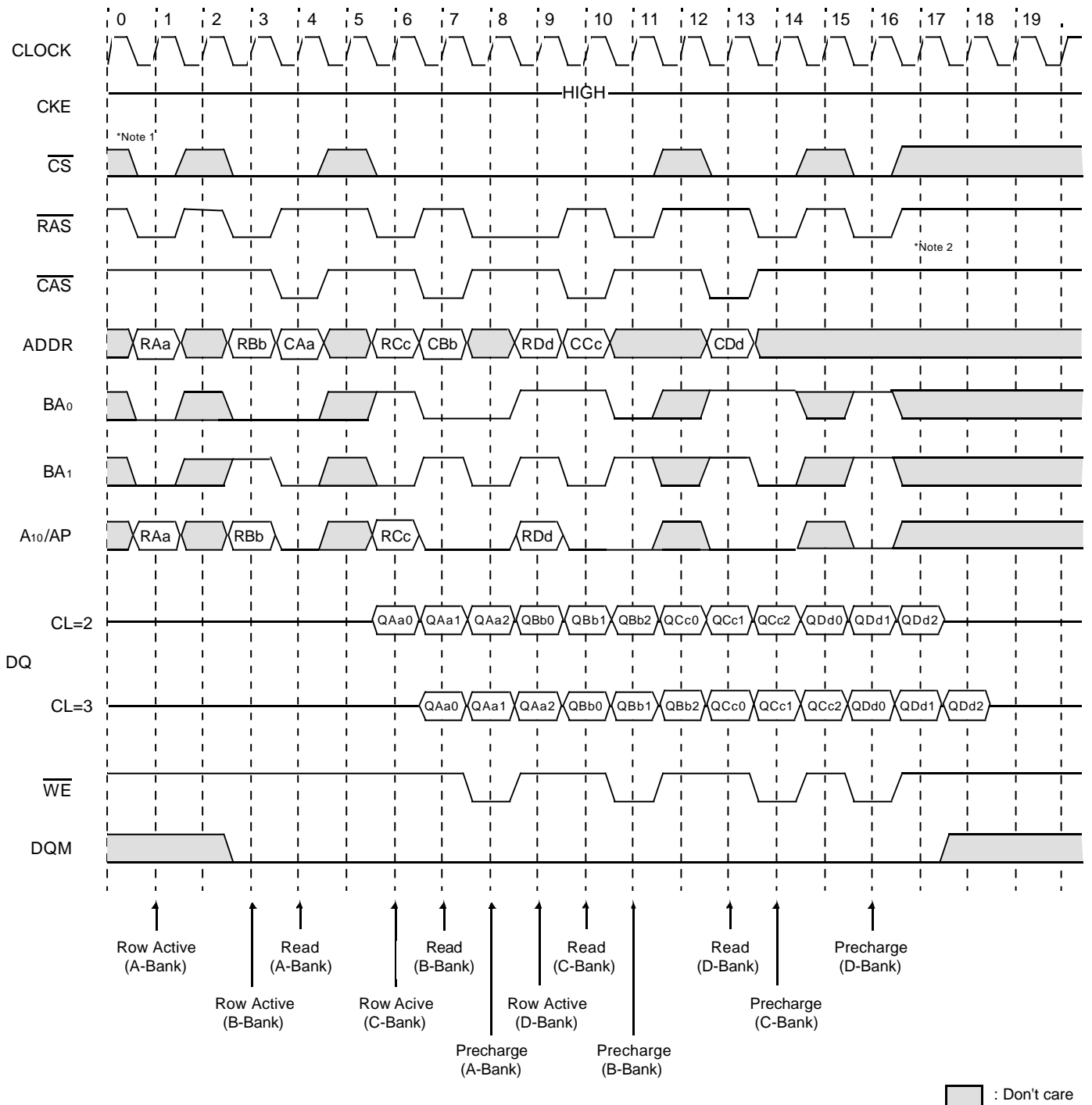

**\*Note :** 1.  $\overline{CS}$  can be don't cared when  $\overline{RAS}$ ,  $\overline{CAS}$  and  $\overline{WE}$  are high at the clock high going dege.  
 2. To interrupt a burst read by row precharge, both the read and the precharge banks must be the same.



# TIMING DIAGRAM

# CMOS SDRAM

Page Write Cycle at Different Bank @Burst Length=4, tRDL=1CLK

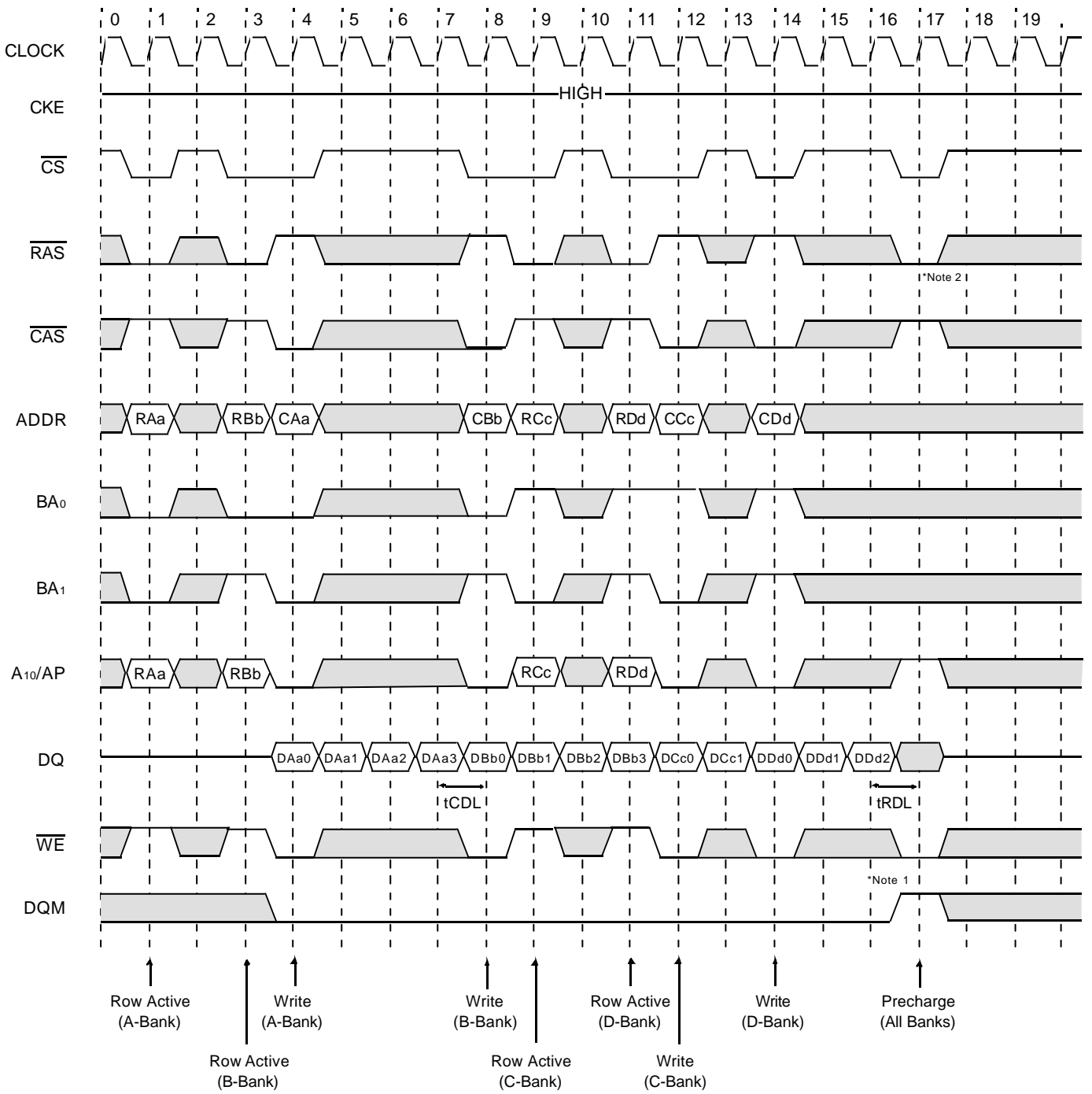

□ : Don't care

- \*Note :**
1. To interrupt burst write by Row precharge, DQM should be asserted to mask invalid input data.
  2. To interrupt burst write by Row precharge, both the write and the precharge banks must be the same.



# TIMING DIAGRAM

# CMOS SDRAM

Page Write Cycle at Different Bank @Burst Length=4, tRDL=2CLK

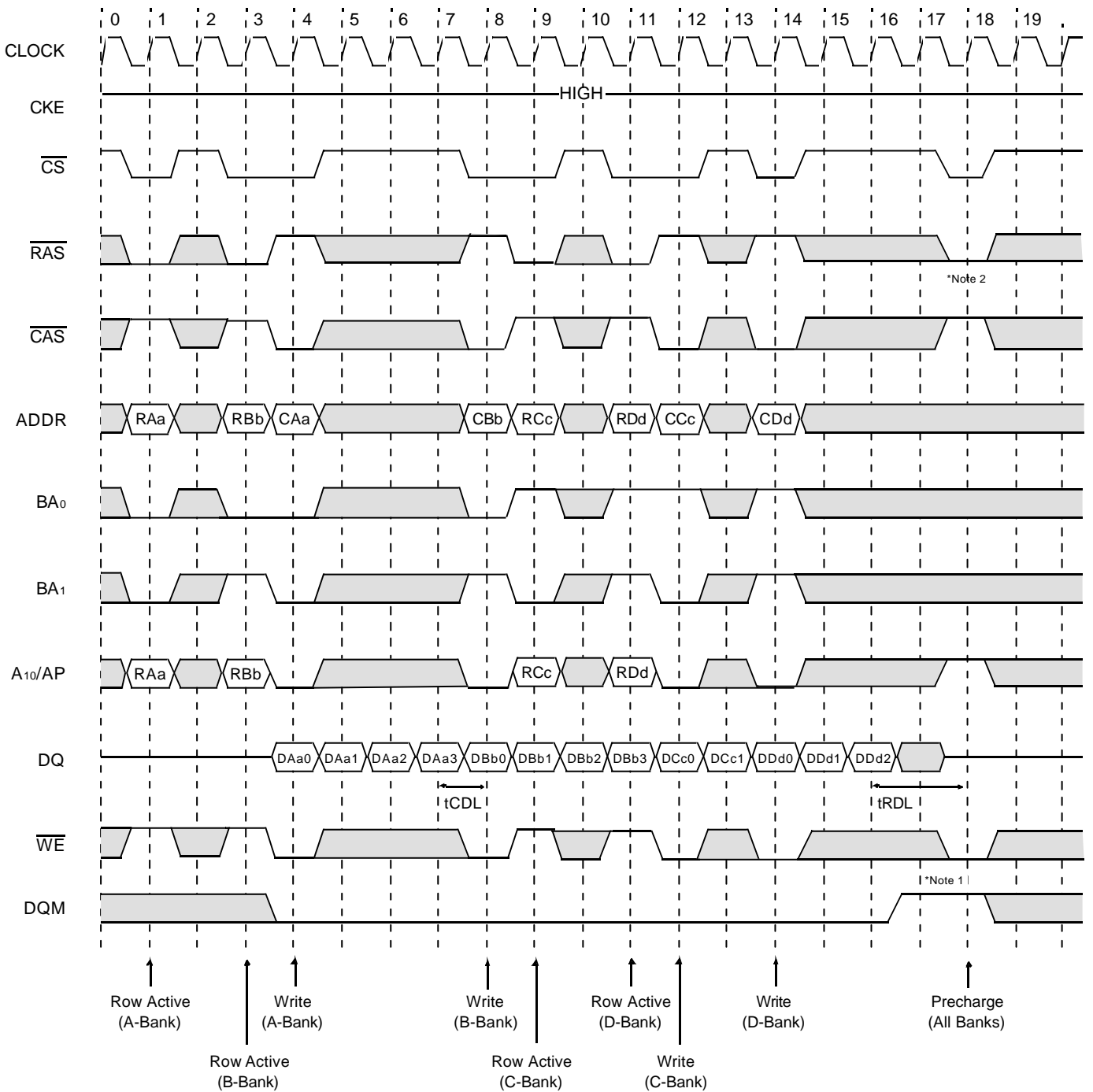

**\*Note :** 1. To interrupt burst write by Row precharge, DQM should be asserted to mask invalid input data.  
 2. To interrupt burst write by Row precharge, both the write and the precharge banks must be the same.



# TIMING DIAGRAM

# CMOS SDRAM

## Read & Write Cycle at Different Bank @Burst Length=4

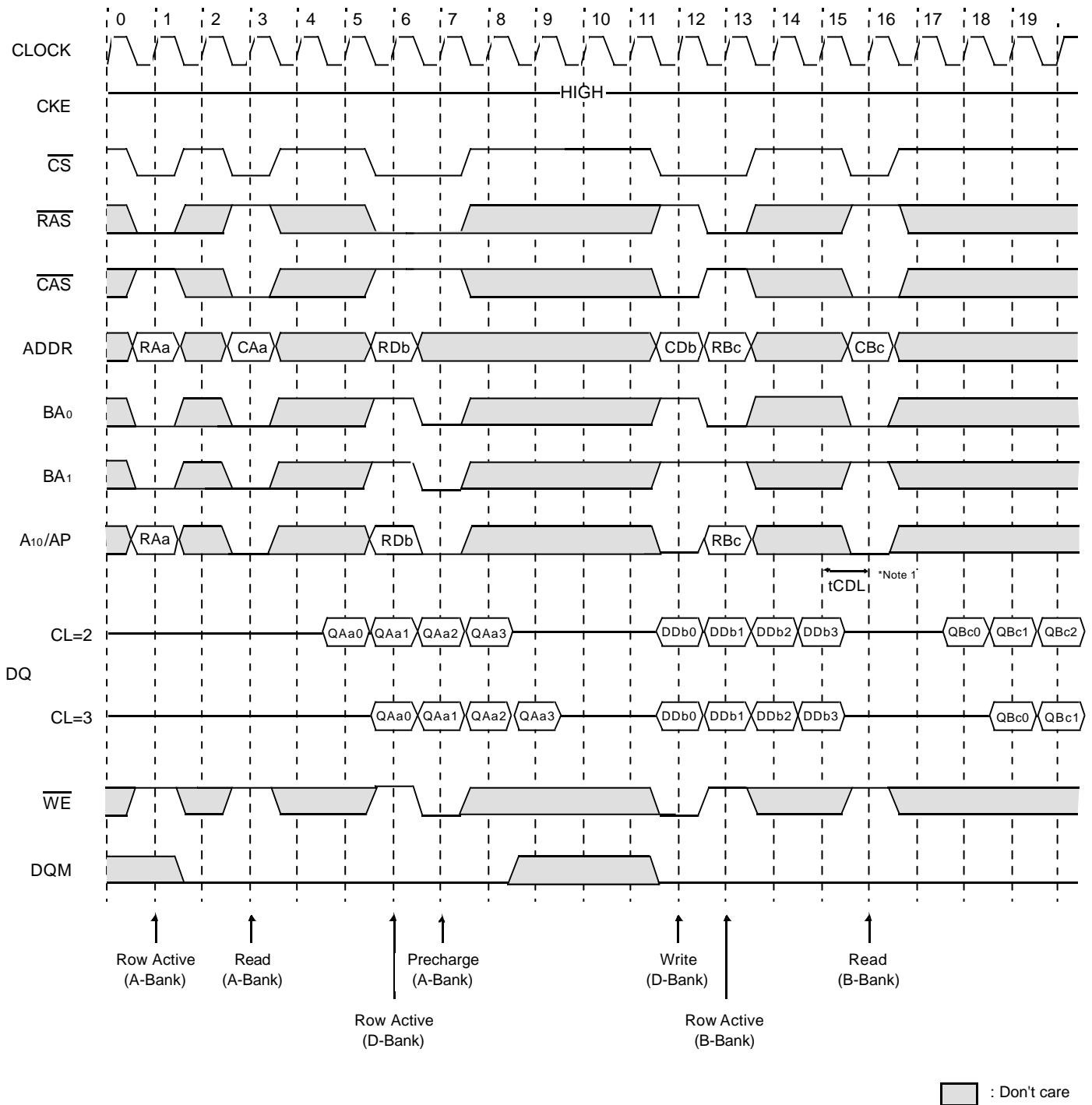

\*Note : 1.  $t_{CDL1}$  should be met to complete write.



ELECTRONICS

# TIMING DIAGRAM

# CMOS SDRAM

## Read & Write Cycle with Auto Precharge I @Burst Length=4

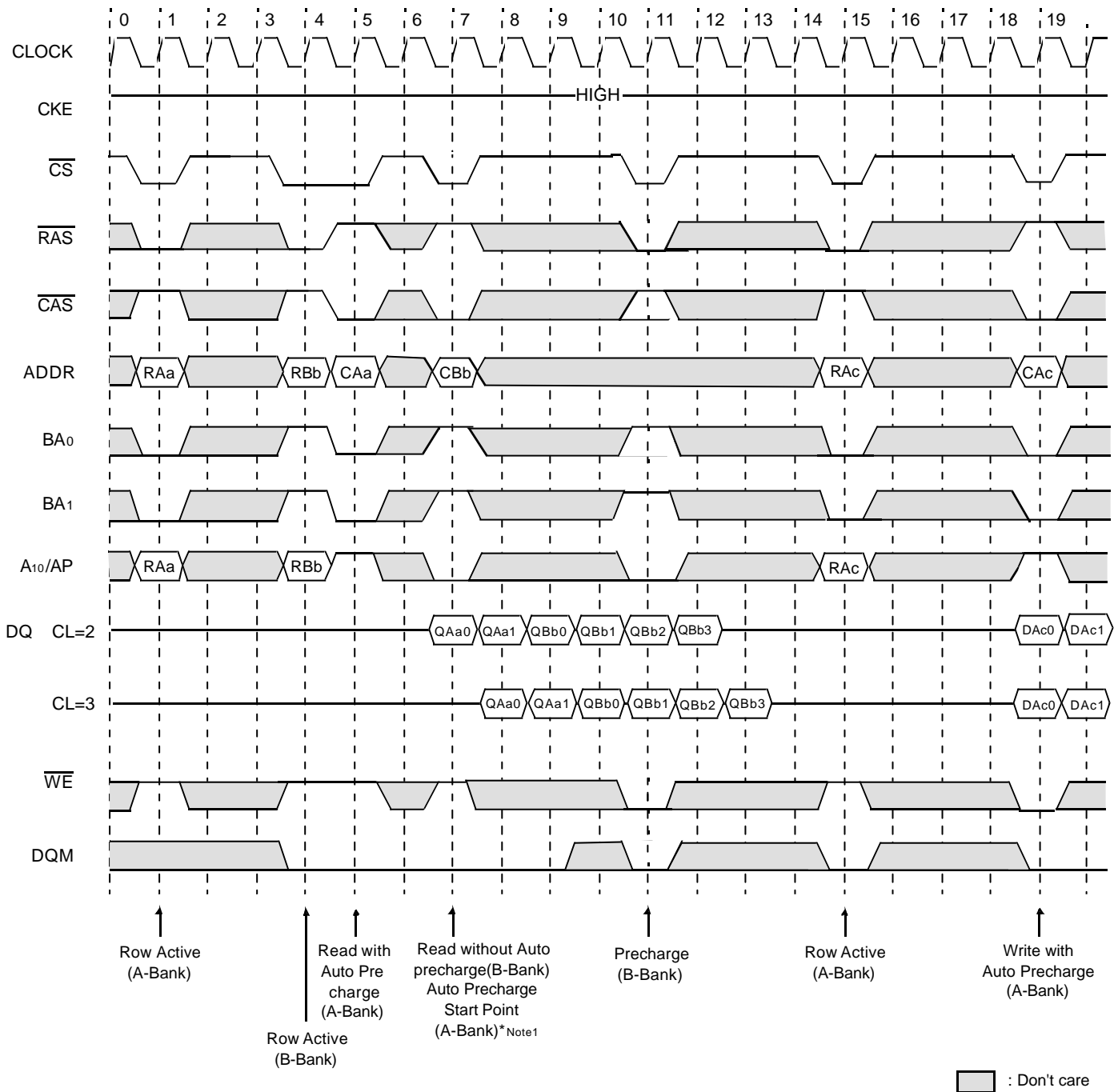

- \*Note1:** When Read(Write) command with auto precharge is issued at A-Bank after A and B Bank activation.
- if Read(Write) command without auto precharge is issued at B-Bank before A-Bank auto precharge starts, A-Bank auto precharge will start at B-Bank read command input point .
  - any command can not be issued at A-Bank during tRP after A-Bank auto precharge starts.



# TIMING DIAGRAM

# CMOS SDRAM

## Read & Write Cycle with Auto Precharge II @Burst Length=4

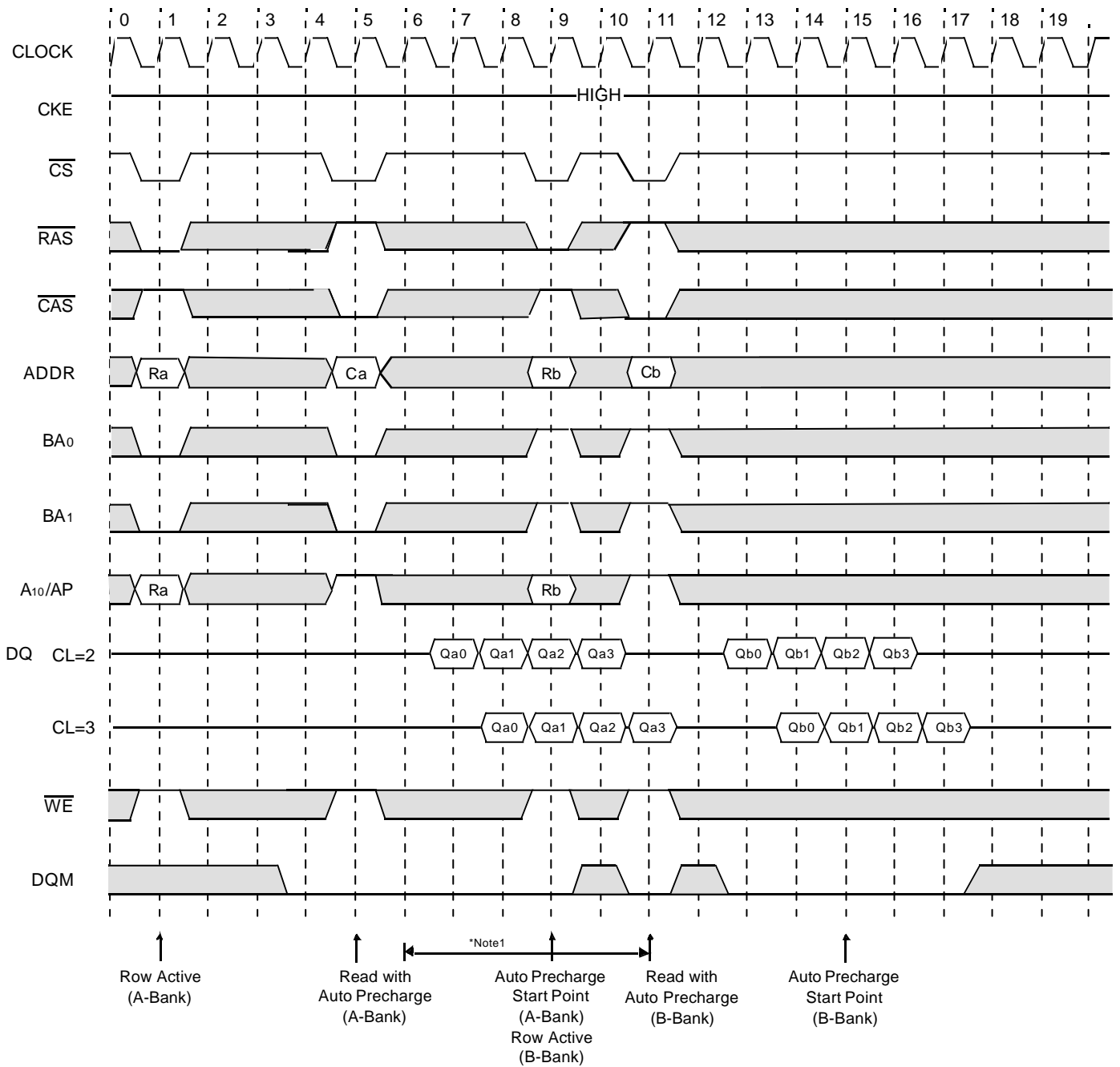

**\*Note 1:** Any command to A-bank is not allowed in this period.  
tRP is determined from at auto precharge start point



# TIMING DIAGRAM

# CMOS SDRAM

Clock Suspension & DQM Operation Cycle @CAS Latency=2, Burst Length=4

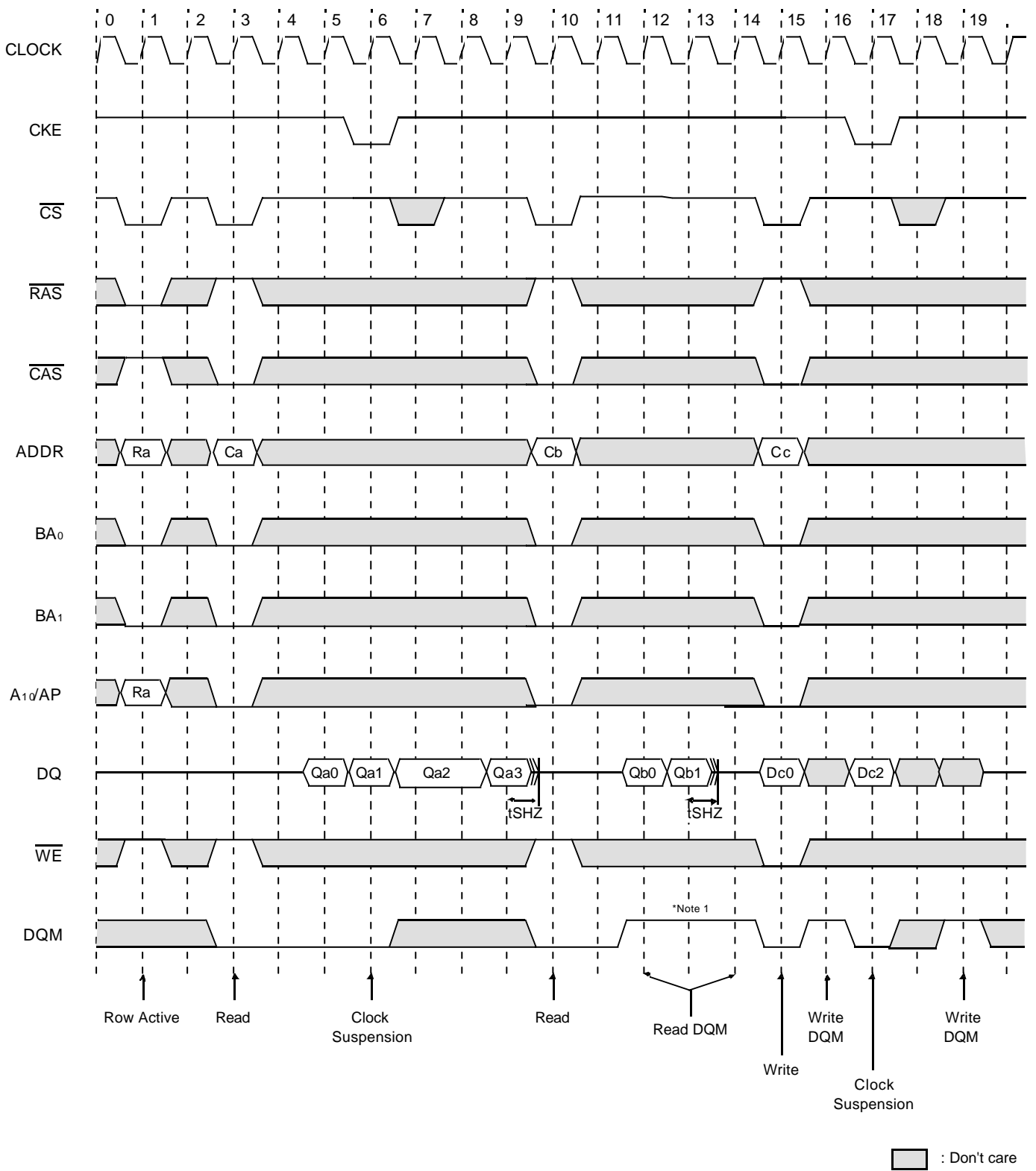

\*Note1 : DQM is needed to prevent bus contention.



ELECTRONICS



# TIMING DIAGRAM

# CMOS SDRAM

## Read Interrupted by Precharge Command & Read Burst Stop Cycle @ Full Page Burst

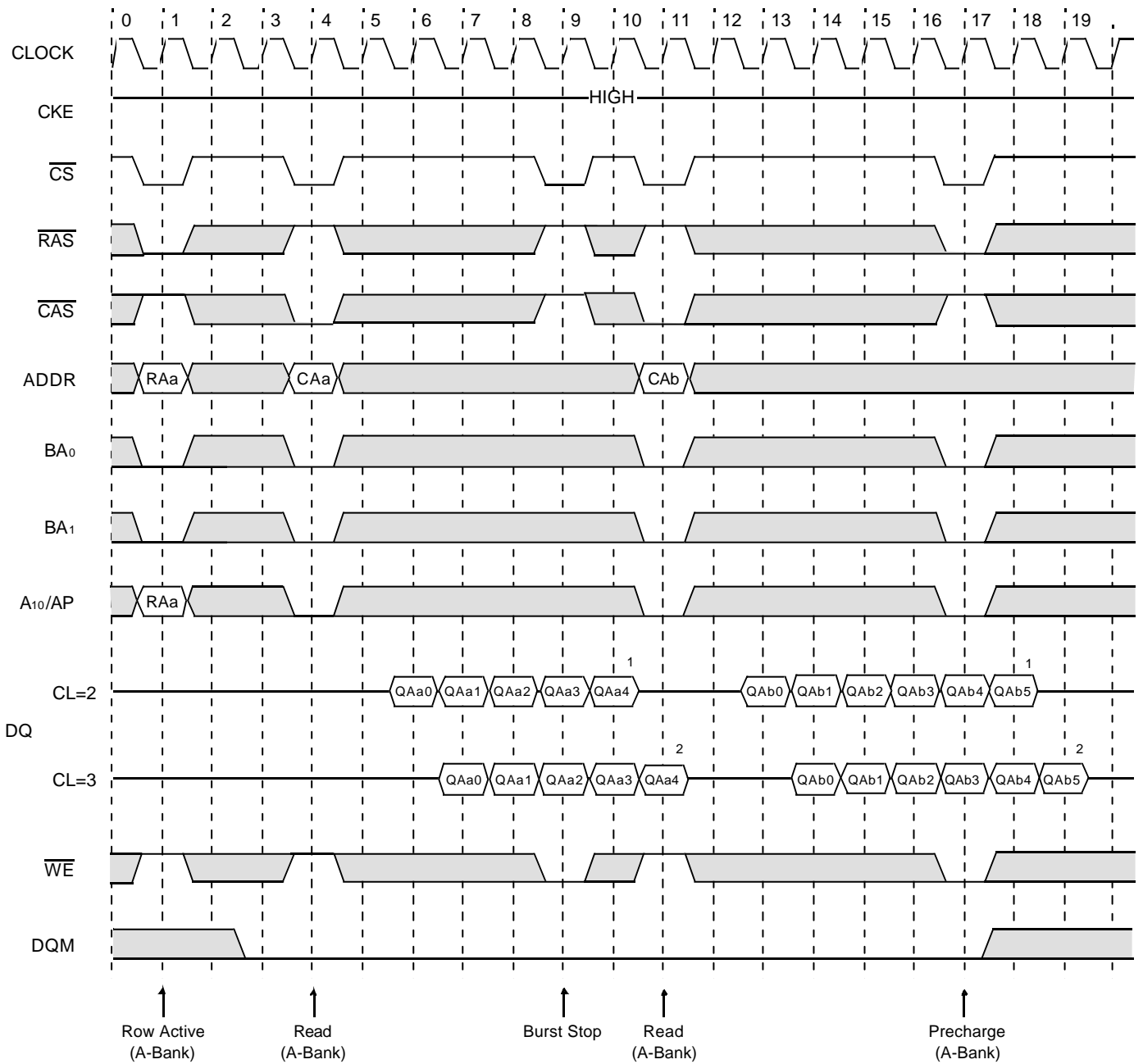

□ : Don't care

- \*Note :**
- At full page mode, burst is finished by burst stop or precharge.
  - About the valid DQs after burst stop, it is same as the case of RAS interrupt. Both cases are illustrated above timing diagram. See the label 1, 2 on them. But at burst write, Burst stop and RAS interrupt should be compared carefully. Refer the timing diagram of "Full page write burst stop cycle".
  - Burst stop is valid at every burst length.



ELECTRONICS

# TIMING DIAGRAM

# CMOS SDRAM

## Write Interrupted by Precharge Command & Write Burst Stop Cycle @ Full Page Burst, $t_{RDL}=1CLK$

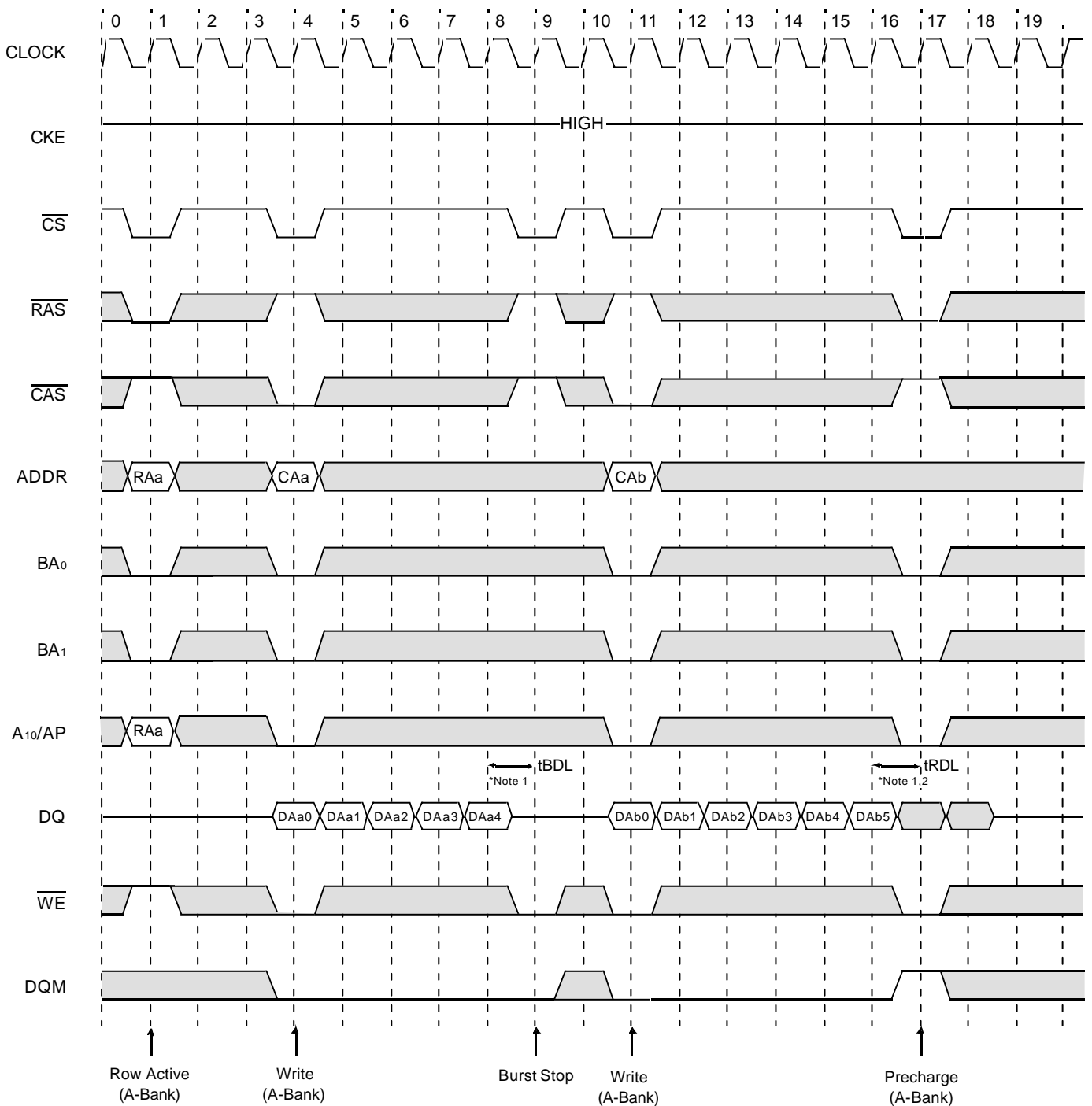

- \*Note :**
1. At full page mode, burst is finished by burst stop or precharge.
  2. Data-in at the cycle of interrupted by precharge can not be written into the corresponding memory cell. It is defined by AC parameter of  $t_{RDL}$ .  
DQM at write interrupted by precharge command is needed to prevent invalid write.  
DQM should mask invalid input data on precharge command cycle when asserting precharge before end of burst. Input data after Row precharge cycle will be masked internally.
  3. Burst stop is valid at every burst length.

□ : Don't care



ELECTRONICS

# TIMING DIAGRAM

# CMOS SDRAM

## Write Interrupted by Precharge Command & Write Burst Stop Cycle @ Full Page Burst, $t_{RDL}=2CLK$

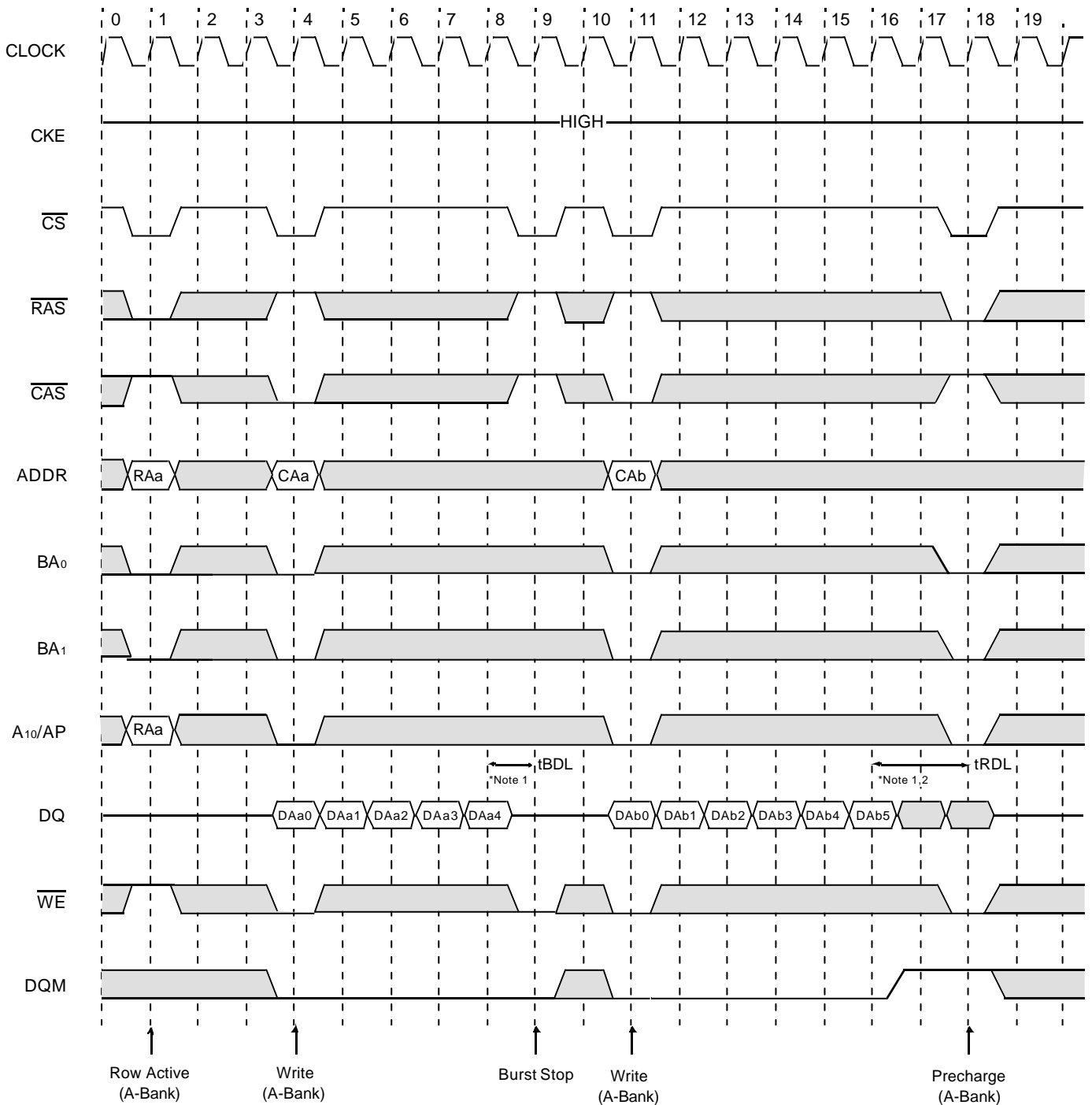

- \*Note :**
1. At full page mode, burst is finished by burst stop or precharge.
  2. Data-in at the cycle of interrupted by precharge can not be written into the corresponding memory cell. It is defined by AC parameter of  $t_{RDL}$ .  
DQM at write interrupted by precharge command is needed to prevent invalid write.  
DQM should mask invalid input data on precharge command cycle when asserting precharge before end of burst. Input data after Row precharge cycle will be masked internally.
  3. Burst stop is valid at every burst length.

□ : Don't care



ELECTRONICS

# TIMING DIAGRAM

# CMOS SDRAM

## Burst Read Single bit Write Cycle @Burst Length=2

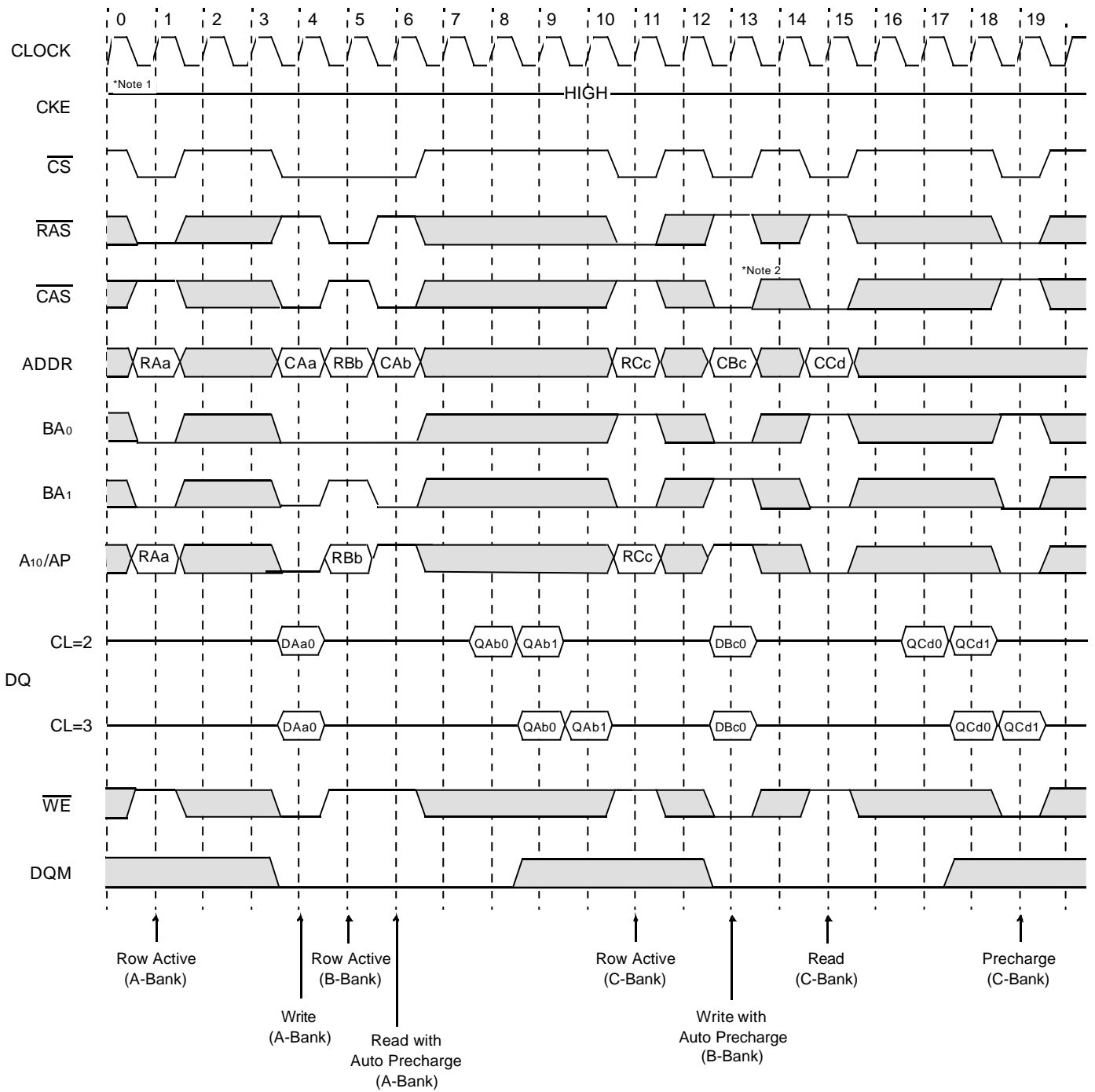

- \*Note :**
1. BRSW modes is enabled by setting A<sub>9</sub> "High" at MRS (Mode Register Set).  
At the BRSW Mode, the burst length at write is fixed to "1" regardless of programmed burst length.
  2. When BRSW write command with auto precharge is executed, keep it in mind that t<sub>RAS</sub> should not be violated.  
Auto precharge is executed at the burst-end cycle, so in the case of BRSW write command, the next cycle starts the precharge.



# TIMING DIAGRAM

# CMOS SDRAM

Active/Precharge Power Down Mode @CAS Latency=2, Burst Length=4

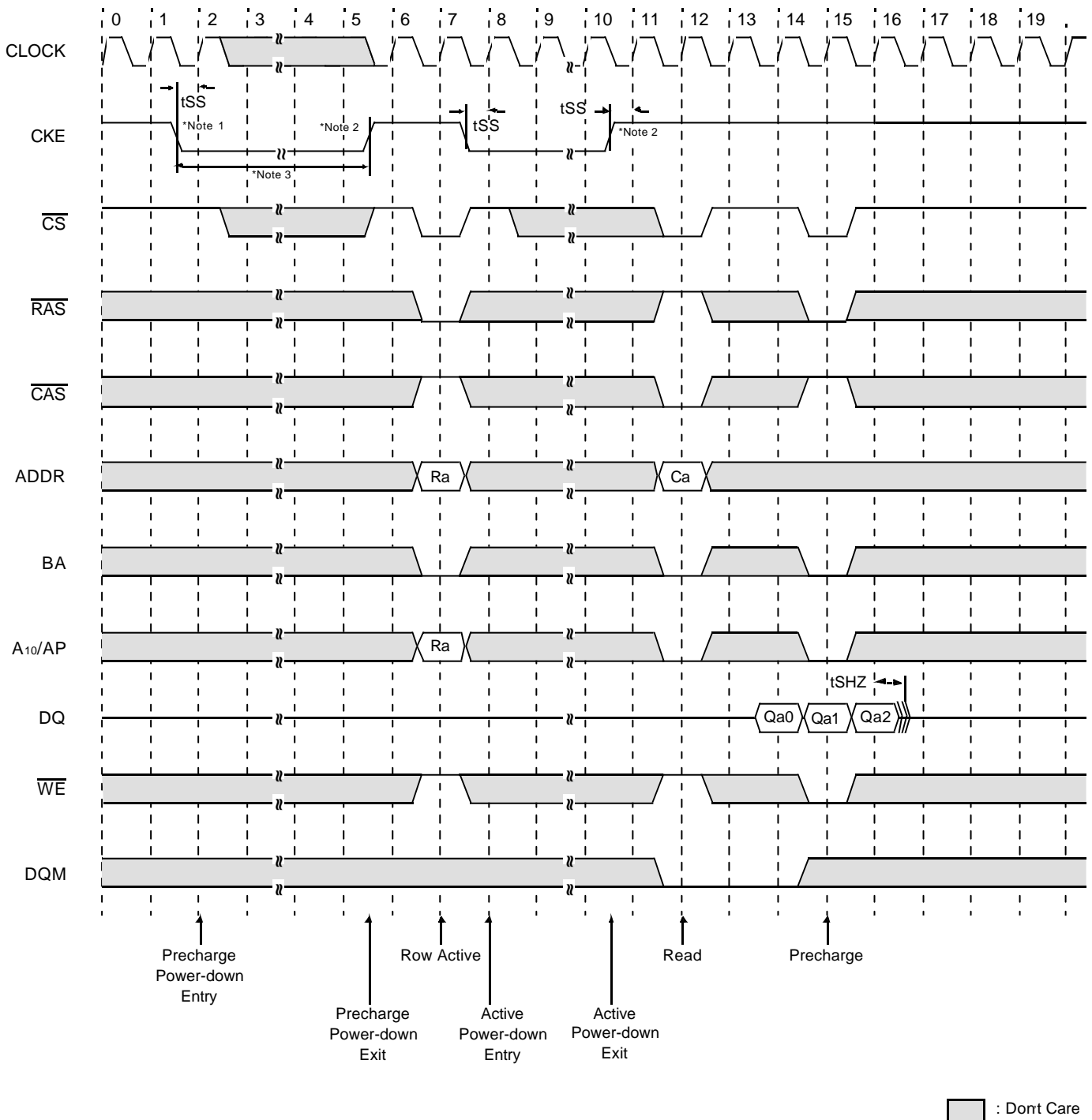

- \*Note :**
1. Both banks should be in idle state prior to entering precharge power down mode.
  2. CKE should be set high at least  $1\text{CLK} + t_{SS}$  prior to Row active command.
  3. Can not violate minimum refresh specification. (64ms)



ELECTRONICS

## Self Refresh Entry & Exit Cycle

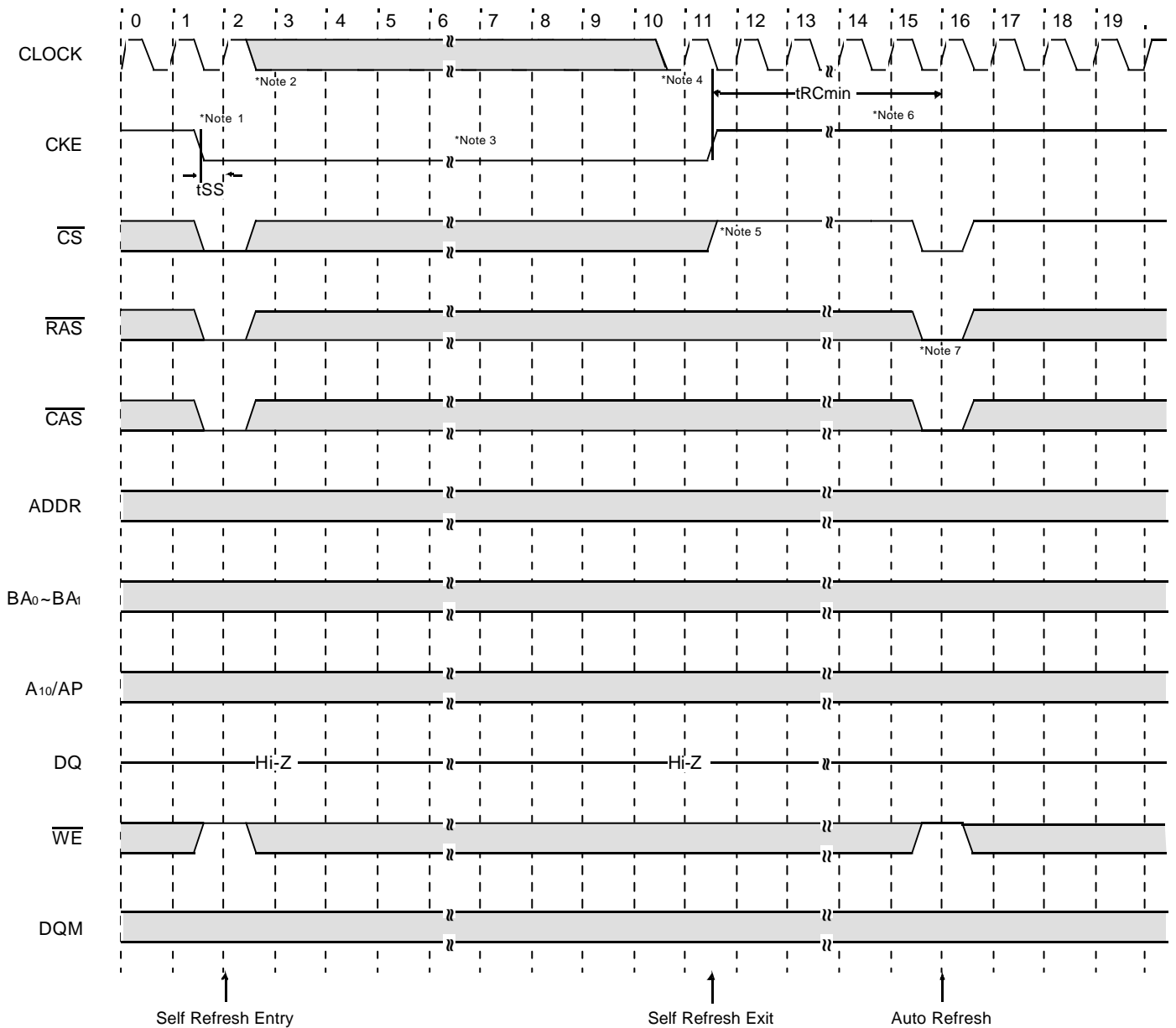

□ : Don't care

**\*Note :** TO ENTER SELF REFRESH MODE

1.  $\overline{CS}$ ,  $\overline{RAS}$  &  $\overline{CAS}$  with CKE should be low at the same clock cycle.
2. After 1 clock cycle, all the inputs including the system clock can be don't care except for CKE.
3. The device remains in self refresh mode as long as CKE stays "Low".  
cf.) Once the device enters self refresh mode, minimum  $t_{RAS}$  is required before exit from self refresh.

**TO EXIT SELF REFRESH MODE**

4. System clock restart and be stable before returning CKE high.
5.  $\overline{CS}$  starts from high.
6. Minimum  $t_{RC}$  is required after CKE going high to complete self refresh exit.
7. 4K cycle(64Mb, 128Mb) or 8K cycle(256Mb) of burst auto refresh is required before self refresh entry and after self refresh exit if the system uses burst refresh.

# TIMING DIAGRAM

# CMOS SDRAM

### Mode Register Set Cycle

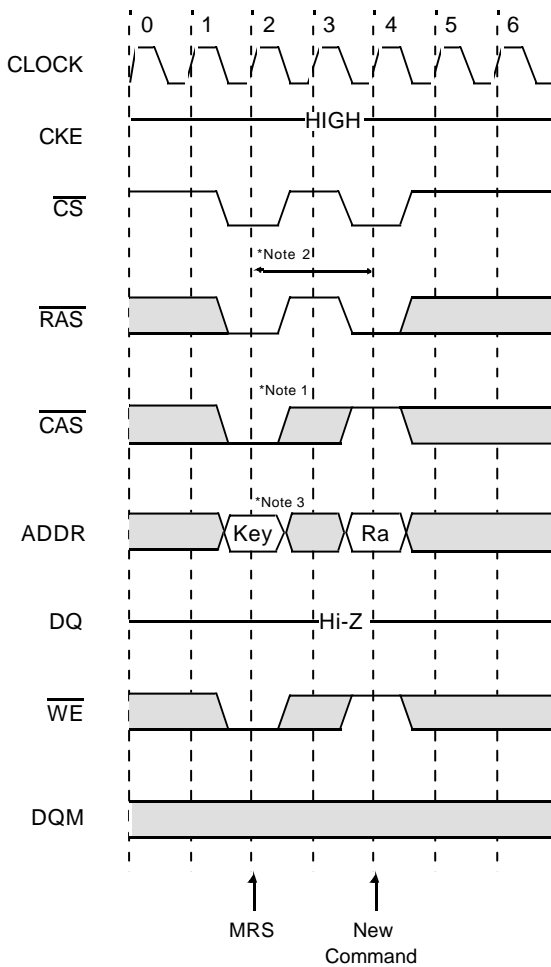

### Auto Refresh Cycle

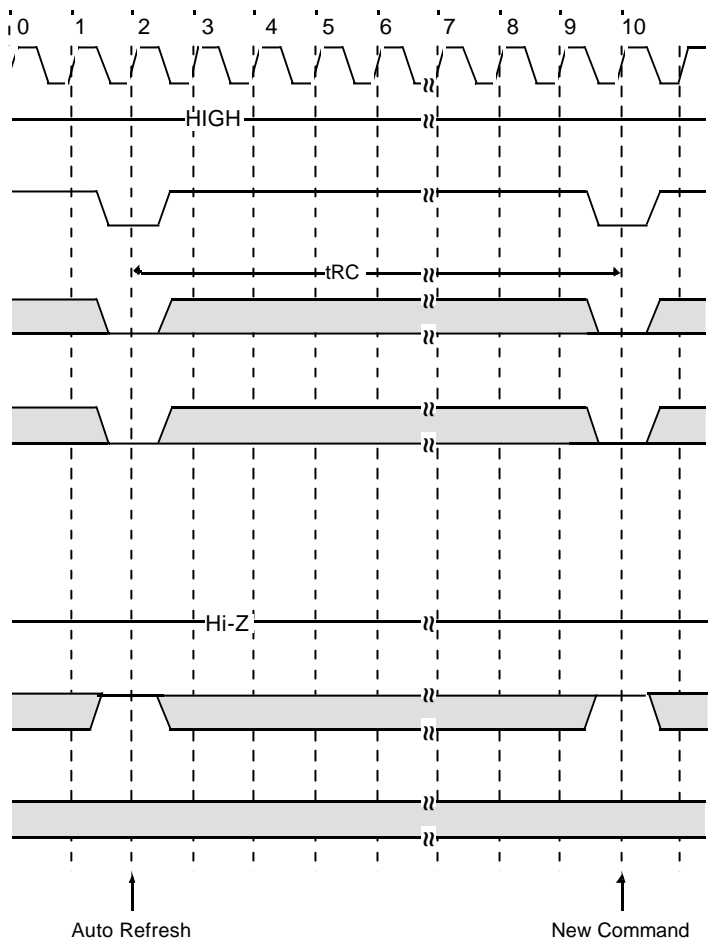

□ : Don't care

\* All banks precharge should be completed before Mode Register Set cycle and auto refresh cycle.

#### MODE REGISTER SET CYCLE

- \*Note :**
1.  $\overline{CS}$ ,  $\overline{RAS}$ ,  $\overline{CAS}$ , &  $\overline{WE}$  activation at the same clock cycle with address key will set internal mode register.
  2. Minimum 2 clock cycles should be met before new  $\overline{RAS}$  activation.
  3. Please refer to Mode Register Set table.



ELECTRONICS